

FläktGroup®

AIRTREND Ltd
Predstavništvo u Beogradu
Kumanovska 14, 11000 Beograd
Tel: 011/3836886, 3085740
Faks: 011/3444113
e-mail: gobrid@eunet.rs
web: www.airtrend.rs

eCO TOP®

INSTALLATION AND MAINTENANCE MANUAL



CONTENTS

	Page		Page
1. SAFETY INSTRUCTIONS	3	10. CONTROL FUNCTIONS	
VDI 6022	3	10.1 Rotor, heating and cooling	29
2. DESCRIPTION OF THE UNIT	4	10.2 Temperature controls	29
3. TRANSPORT AND PLACEMENT	5	10.3 Freeze protection	31
4. CONNECTIONS		10.4 Defrost function	31
4.1 Duct connections	6	10.5 Cooling recovery	31
4.2 Post heater, electrical (9 kW)	6	10.6 Night cooling	31
4.3 Post heater, hot water	6	10.7 Pressure or Constant flow control	32
4.4 Cooling coil, water	7	11. COMMUNICATION	
4.5 Valve and valve actuator	7	11.1 Modbus, RS485	33
4.6 Damper	7	11.2 Modbus, TCP/IP	33
4.7 Silencer	7	11.3 Webserver	33
5. ELECTRICAL CONNECTIONS		12. PARAMETER LIST	34
5.1 Fuse protection	8	13. MAINTENANCE	
5.2 Electrical data	8	13.1 General	40
5.3 Main supply	8	13.2 Filter	40
5.4 Connection of control panel	9	13.3 Rotary Heat Exchanger	41
6. CONNECTION OF EXTERNAL COMPONENTS		13.4 Post heater, hot water	42
6.1 Electrical post heater (Size 06, 9 kW)	10	13.5 Post heater, electrical	43
6.2 Post heater, hot water	10	13.6 Cooling coil, water	43
6.3 Cooling coil, water	10	13.7 Fans	44
6.4 Cooling coil, DX	10	13.8 Service schedule	45
6.5 Damper	10	14. DECLARATION OF CONFORMITY	46
6.6 Temperature sensors	11	15. DISPOSAL	47
6.7 Extended / Forced ventilation	11		
6.8 Fire protection function	11		
6.9 Summary alarm	11		
7. WIRING DIAGRAMS	12		
8. TESTING OF FUNCTIONS	15		
9. CONTROL PANEL, OPERATIONS, COMMISSIONING			
9.1 General	16		
9.2 Home screen overview	17		
9.3 Sub menus	19		
9.4 Date/time, language	20		
9.5 Advanced settings for installers and service personnel	21		
9.6 Commissioning Wizard	22		
9.7 Schedules	26		

1. SAFETY INSTRUCTIONS

OPERATION OF AIR HANDLING UNITS AND ACCESSORIES

WARNING



Before taking the air handling unit into operation fit any unused connections with protective mesh.



In addition, all electrotechnical and mechanical safety devices must be installed before taking the air handling unit into operation.

- Before opening the unit check that its power has been disconnected.
- Take care when opening the isolating valves for the hot water to the air heater. There is a risk of water hammer or steam discharge.
- When servicing or inspecting the unit, turn off the safety switch before opening the inspection doors. Reset all safety devices before restarting.
- The clearance in front of electric heaters and electrical cabinets shall conform to applicable electrical safety regulations.
- Use the control panel to stop the unit.
- The unit's hatches are fitted with locking handles. Ensure that the unit is always left locked, and that the keys cannot be accessed by unauthorized persons.
- Do not open inspection hatches when the unit is in operation.
- Use protective gloves during installation and service.

Installation may only be carried out by qualified personnel.

VDI 6022

eCO TOP is designed in accordance to hygiene standard VDI 6022 and



is easy to clean with no place where dirt can accumulate. Non-metallic part, have been chosen as proven free of micro bacterial or mold growth.

Following the VDI 6022, AHU should ensure a physiologically favourable indoor climate and a hygienically perfect indoor air quality.

The eCO TOP is designed in order, not to endanger health, not to disturb the condition and the thermal comfort, not to lead to odour nuisance and to prevent exposure and impact of inorganic and organic pollutants.

The casing is approved for T2 / TB2 / L1 (M) / D1 (M).



2. DESCRIPTION OF THE UNIT

COMPONENTS

The unit can be supplied in left-hand or right-hand configurations. Refer to the order code in Technical Instruction.

LEFT HAND CONFIGURATION

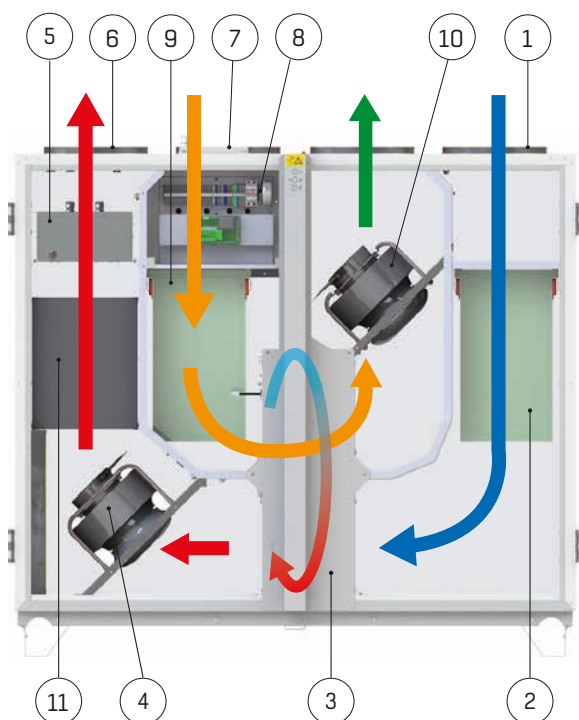

- 1 Outdoor air sensor GT3
- 2 Supply filter
- 3 Rotary heat exchanger with rotation sensor
- 4 Supply fan
- 5 Electrical heater including overheating protection alternatively hot water coil with freeze protection GT5

FANS

The unit has two plug fans with EC motors.

ROTARY HEAT EXCHANGER

The speed controlled rotor is fitted with a purge sector and a rotation sensor.

FILTER

Bag filter class F7 on both supply and extract air.

POST HEATER, HOT WATER

Hot water coil containing copper tubes and aluminum fins. Pipe connection \varnothing 15 mm. Freeze protection temperature sensor is included. Max operating pressure 1.6 MPa.

RIGHT HAND CONFIGURATION

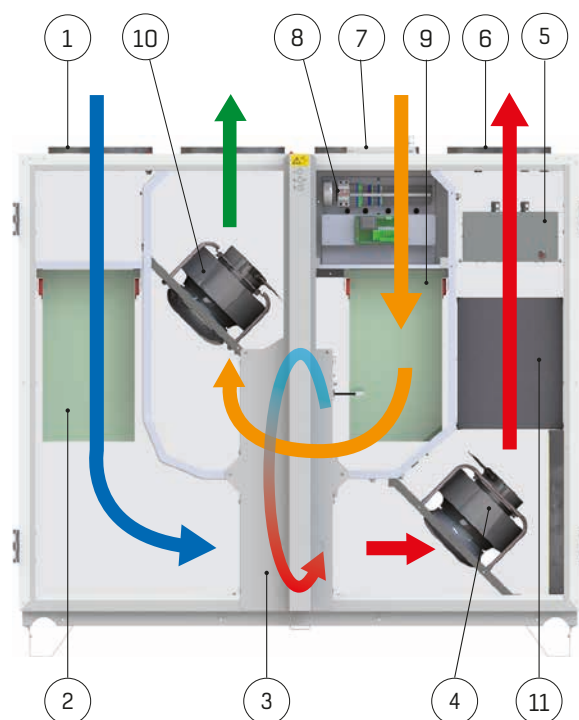

- 6 Supply air sensor GT1
 - 7 Extract air sensor GT12
 - 8 Control equipment
 - 9 Extract filter
 - 10 Exhaust fan
 - 11 Internal silencer (accessory)
- ➔ Outdoor air
➔ Supply air
➔ Extract air
➔ Exhaust air

POST HEATER, ELECTRICAL

The heater for size 03 and 04 is built-in. For size 06 the heater is duct mounted.

CONTROL SYSTEM

The ISYteq Mini control system is integrated with the unit and is ready for use with a large number of functions.

INTERNAL SILENCER (ACCESSORY)

An internal silencer can be fitted in the supply air inside the unit.

3. TRANSPORT AND PLACEMENT

TRANSPORT

Use a fork lift truck, pallet truck or platform trolley for transport on site. The unit can be lifted from the front or from the side.

To move size 06 through a 900 mm opening remove the door and the center strut. See section 13.3.

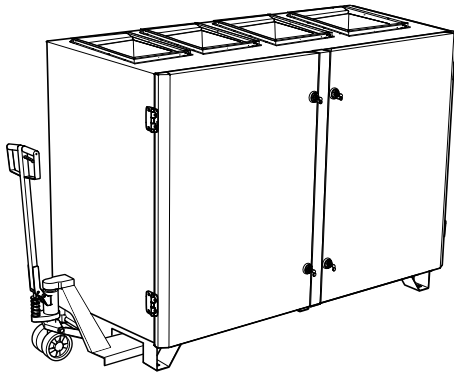

PLACEMENT

The unit can be placed directly onto the surface if this is flat and horizontal, otherwise use adjustable feet.

Available as accessory RDTZ-13.



UNIT WEIGHT

Size 03 = 260 kg

Size 04 = 300 kg

Size 06 = 400 kg

SPACE REQUIREMENTS

Make sure that it is enough space around the unit for routine service work, such as replacing filters and cleaning the fan and casing.

Consideration has to be taken for future replacement of components.

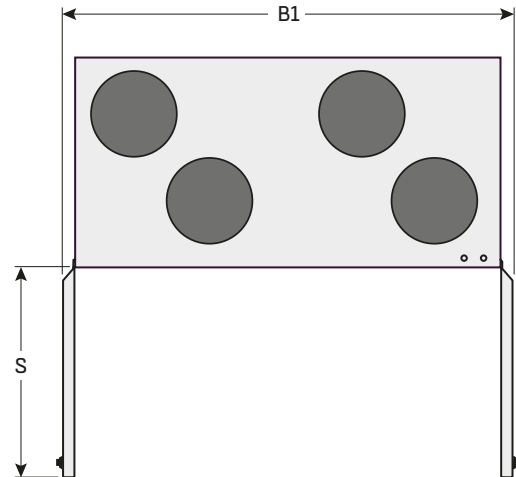

Size	B1	S
03	1690	760
04	1840	840
06	2110	970

B1 = width with open doors
S = minimum space for service*)

* in front of the control cabinet there has to be enough space according to local electrical regulations.

SOUND TRANSMISSION

When a unit is positioned next to a wall, low frequency sound can generate vibrations in the wall, even if the sound level from the unit is acceptable. Generally the unit should be positioned against a wall adjacent to a room that is not sensitive for noise. When this is not possible the unit should be positioned 400-500 mm from the wall.

Duct lead-through must be designed with care so that rigid connections between the duct and wall do not occur. In addition, the seal around the duct must be carefully installed to prevent the transmission of noise to adjacent areas. For sensitive installations it may be a good idea to connect ducts using flexible connections.

If the floor structure is weak, noise can be transmitted to other areas in the building. Use of a heavy insulating mat can prevent that problem.

4. CONNECTIONS

4.1 DUCT CONNECTIONS

Size 03 (Ø250 mm) and 04 (Ø315 mm) have circular duct connections. Size 06 has rectangular duct connections (600 x 300 mm).

NOTE! The weight of the duct system with components must not lay weight on the unit.

4.2 POST HEATER, ELECTRICAL

The electrical post heater for size 06 is duct mounted, see separate instruction.

4.3 POST HEATER, HOT WATER

Connect the pipes for the heating coil inside the unit according to pictures below. View from top.

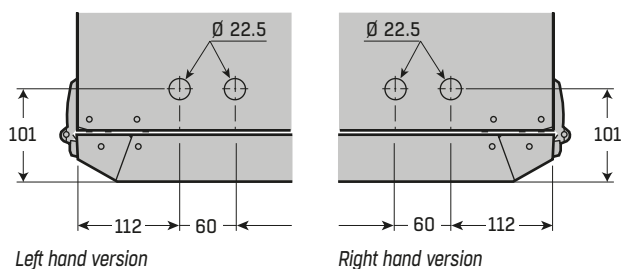

Pipe connections. Freeze protection sensor is factory mounted on the outlet pipe of the coil. Right hand version shown.

PIPE CONNECTION

Size 03 = 3/8"

Size 04 = 12 mm

Size 06 = 12 mm

Maximum operating pressure 1,0 MPa

PREVENTING FREEZING

There is a risk of freezing in the hot water coil at low outdoor temperatures. This can cause water damage. The risk can appear:

1. if the temperature of the water is too high. The risk increases in spring and autumn. Adjust the water temperature in relation to the outdoor air temperature.
2. if the post heater is oversized. Decrease the temperature of the water to increase the water flow.

NOTE! To avoid freezing the temperatures for frost protection must not be set too low. If the building has to be left unheated for long periods during winter, the water must be drained from both the pipework and the heating coil.

FINS

Any deformed fins can be adjusted using fin comb EQAZ-14.



WARNING! Wear protective gloves when using a fin comb.

VENTING

The air must be properly vented from the system to ensure good function. The venting is made through the pipe system.



Warning - hot water!!

FläktGroup takes no responsibility neither for the connection of air heaters to the heating system, nor for damage or injury caused by incorrect planning, installation or maintenance of this system. Pipework, valves etc. are to be designed due to pressure drop and function, not the dimensions of the air heater connections. The weight of the pipe work system with components must not lay weight on the water coil.

4. CONNECTIONS

4.4 COOLING COIL, WATER

The cooling coils have circular duct connections with rubber ring seals. For size 06 a converter from rectangular to circular is available as an accessory (RDTZ-24). The cooler has to be installed horizontally and the distance to nearest bend has to be at least 600 mm. Venting and draining is carried out via the pipe system. The pipe connection, \varnothing 22 mm, is located on the outlet end, is smooth and is intended for a compression fitting. The drainage tray is in stainless steel and has an R 1/2" connection. Maximum operating pressure 1.0 MPa and maximum operating temperature 150° C.

4.5 VALVE AND VALVE ACTUATOR

ACTUATORS FOR HEATING SV1 AND COOLING SV2

Connected to terminal in electrical cabinet. Stroke length 5.5 mm. Intended for assembly on 2-way and 3-way valves of the type VVG44 or VXG44.

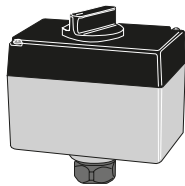

ACCEPTED INSTALLATION METHODS

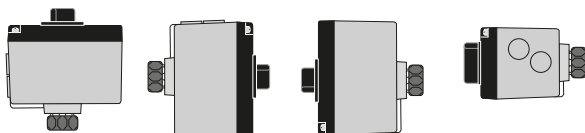

VALVE FOR HEATING AND COOLING

The valve and valve actuator can be easily installed without special tools. A particle filter should be fitted before the valve to extend its service life.

2-WAY VALVE VVG

The flow is increased by turning the spindle inwards, the flow is reduced by moving the spindle outwards. Note that the 2-way valve cannot be used as a 3-way valve.

The flow direction is indicated by an arrow.

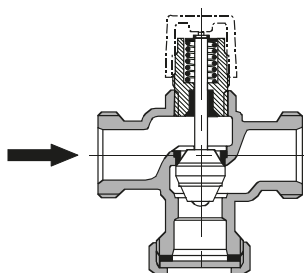

ACCEPTED INSTALLATION METHODS

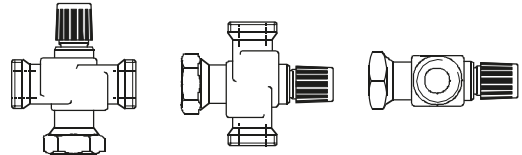

3-WAY VALVE VXG

The bypass is closed by turning the spindle inwards, the bypass is opened by turning the spindle outwards.

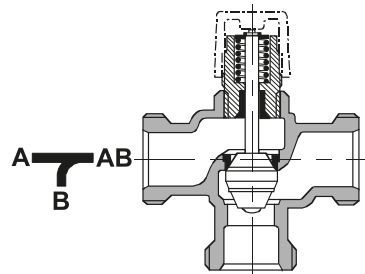

ACCEPTED INSTALLATION METHODS

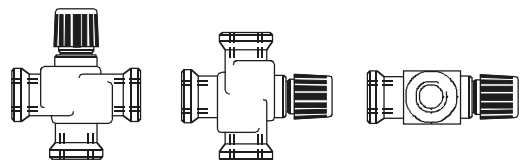

When installing a 3-way valve check as follows:

Mixture from A/B to AB



Splitting from AB to A/B



4.6 DAMPER

Duct mounted damper with a spring return on/off actuator. The actuator has to be connected to the terminal block in the electrical cabinet. Size 03 and 04 have circular duct connections and size 06 has rectangular. The damper is designed for duct insulation of up to 50 mm.

4.7 SILENCER, DUCT MOUNTED

Size 03 and 04 have circular duct connections and size 06 has rectangular. Fire resistance rating EI30. The distance to the fan has to be at least 300 mm.

5. ELECTRICAL CONNECTIONS

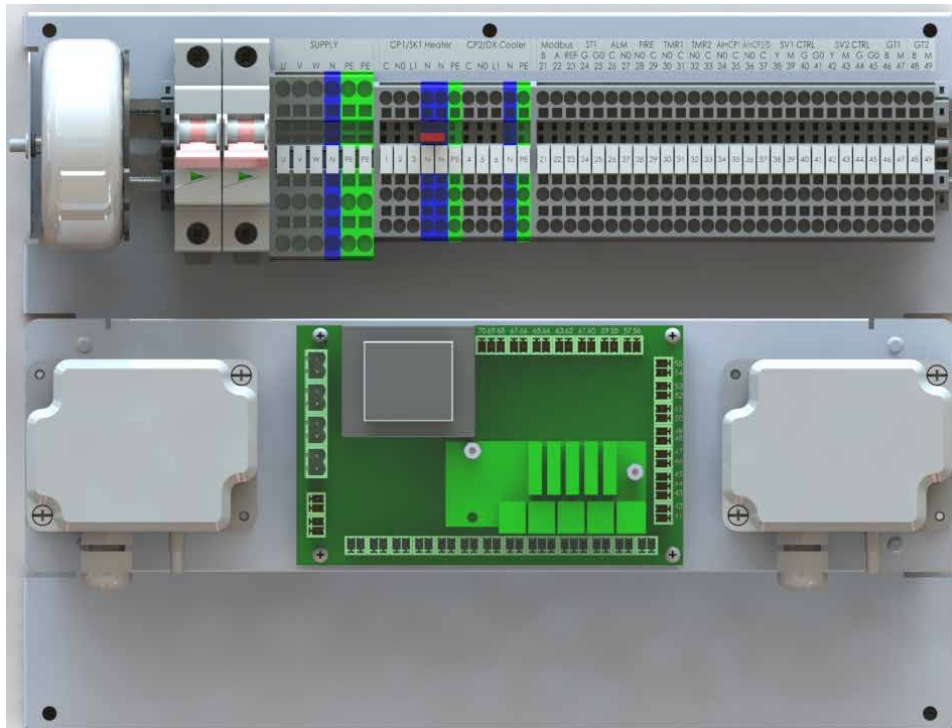

5.1 FUSE PROTECTION

Size	Unit with	Hot water coil	Electrical coil
03	Supply	1 x 230 V	3 x 400 V
	Fuse	10 A	10 A
04	Supply	1 x 230 V	3 x 400 V
	Fuse	10 A	16 A
06	Supply	1 x 230 V	1 x 230 V ¹⁾
	Fuse	10 A	10 A

¹⁾ Duct mounted heater size 06 has sparate supply.

5.2 ELECTRICAL DATA

MOTORS

Size	Power, kW	Current, A
03	0,385 x 2	2,5 x 2
04	0,50 x 2	2,2 x 2
06	0,75 x 2	3,3 x 2

ELECTRICAL POST HEATER

Power, kW	Current, A	Voltage, V
4	10	2 x 400
6	15	2 x 400
9 ¹⁾	13	3 x 400

¹⁾ Duct mounted heater size 06 has sparate supply.



5.3 MAIN SUPPLY

Units with built-in electrical heater, main supply 3 x 400V.

Units with hot water coil can be supplied with 1 x 230V.

Units with duct mounted electrical heater can be supplied with 1 x 230V.

Units are not available for 3 x 230V.

The main supply cable must be fitted with an external safety switch located close to the unit. Connect main supply to terminals U, V, W, N and PE in the control box.

5. ELECTRICAL CONNECTIONS

5.4 CONNECTION OF CONTROL PANEL

The control panel is connected when delivered from factory and provided with a magnet for easy handling. For wall mounting see below.

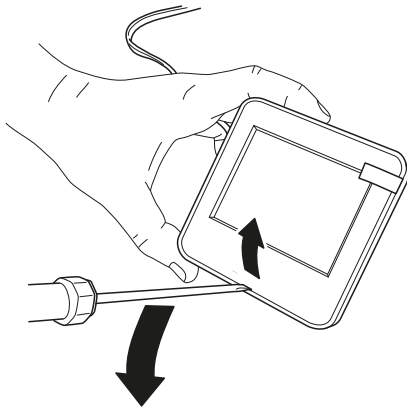

1. Open the control panel using a screwdriver.

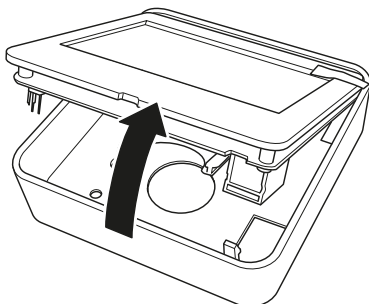

2. Lift the display out of the enclosure.

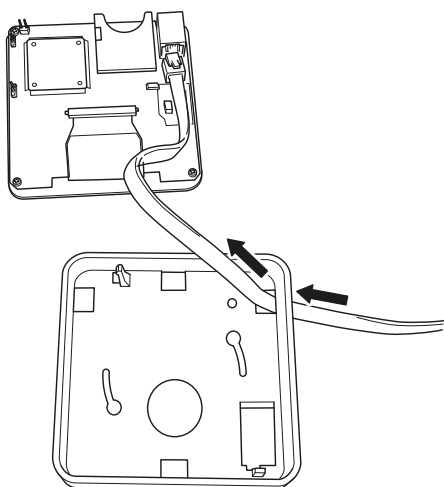

3. Push the connection cable through a suitable hole and if needed make an outlet for the cable in the side of the cover.

4. Mount the enclosure directly on the wall.

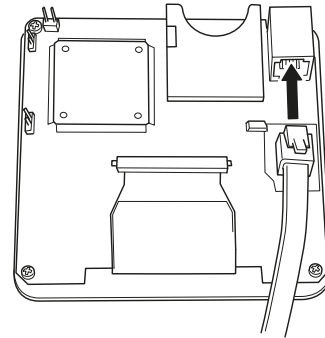

5. Connect the cable to the back of the display as shown above.

Note. Please do not touch the electronics.

6. Push back the display in the enclosure.

NOTE! The control panel is only for indoor use.

6. CONNECTION OF EXTERNAL COMPONENTS

Use the cable flange on the top of the unit to connect all external accessories.

For information about how to connect available accessories see below.

6.1 ELECTRICAL POST HEATER (SIZE 06, 9 KW)

Duct mounted. Separate supply 3 x 400V, 16 A.

Connect alarm, start and control signal to the control box in the unit. eCO TOP is preconfigured for electrical post heater.

(Electrical heater for size 03 and 04 is built-in in the unit, no further connections are needed).

Component	Terminal	Connection	Remark
Electrical heater 9 kW	CP1/SK1 Heater	1 - 2 C - NO	Start signal
	ALM CP1	43 - 44 NO - C	Alarm, overheating (NC)
	SV1 CTRL	35 - 36 Y - M	Control signal 0-10 V
	Supply	3 x 400 V	Not from the unit

6.2 POST HEATER, HOT WATER

Circulation pump (CP1) and valve actuator (SV1) connects according to table below.

Component	Terminal	Connection	Remark
Circulation pump CP1	CP1/SK1 Heater	1 - N - PE	Pump supply (230 V max 2A ¹⁾)
	CP1/SK1 Heater	2 - 3 NO - L1	Loop only with circulation pump
	ALM CP1	43 - 44 NO - C	Voltfree alarm input (NO, configurable)
Valve actuator SV1	SV1 CTRL	35 - 36 - 37 - 38 Y - M - G - GO	

¹⁾ The current consumption for CP1 and CP2 is limited to 2 A.

6.3 COOLING COIL, WATER

Circulation pump (CP2) and valve actuator (SV2) connects according to table below.

Component	Terminal	Connection	Remark
Circulation pump CP2	CP2/DX Cooler	4 - N - PE	Pump supply (230 V max 2A ¹⁾)
	CP2/DX Cooler	5 - 6 NO - L1	Loop only with circulation pump
	ALM CP2/DX	45 - 46 NO - C	Voltfree alarm input (NO, configurable)
Valve actuator SV2	SV2 CTRL	39 - 40 - 41 - 42 Y - M - G - GO	

¹⁾ The current consumption for CP1 and CP2 is limited to 2 A.

6.4 COOLING COIL, DX

The unit can manage cooling DX, 1-step. Note that the coil is not included in the delivery of the unit. For configuration see control functions.

Component	Terminal	Connection	Remark
DX-cooling, 1-step	CP2/DX Cooler	4 - 5 C - NO	Start: 10 % Stop: 0 %
	ALM CP2/DX	45 - 46 NO - C	Voltfree alarm input (NO, configurable)

6.5 DAMPER

On/off actuator with spring return, 15 Nm, 24 VAC.

Component	Terminal	Connection	Remark
Damper	ST1	29 - 30 G - GO	Exhaust air damper if used is connected in parallel (Maximum 2 dampers)

6. CONNECTION OF EXTERNAL COMPONENTS

6.6 TEMPERATURE SENSORS

The unit is provided with:

Supply air sensor GT1, located at supply air spigot.

Outdoor air sensor GT3, located at outdoor air spigot.

Frost protection sensor GT5 (when hot water coil is used), located on the return pipe of the coil.

When using cooling coil or duct mounted post heater a supply temperature sensor (GT1) is supplied for duct mounting. Then there is no supply air sensor mounted in the unit.

Room sensor GT2 (accessory) is supplied when the unit is configured for room temperature control. Then there is no exhaust air sensor mounted in the unit.

The room sensor is intended for wall mounting and needs to have good air circulation and not direct sun light. Cable is not included.

Component	Terminal	Connection	Remark
Supply air sensor	GT1	25 - 26 B - M	Standard sensor is replaced with a duct mounted sensor when using cooling coil or duct mounted heater
Room sensor	GT2	27 - 28 B - M	Replaces exhaust air sensor GT12 when room control is selected

6.7 EXTENDED / FORCED VENTILATION

For external electronic timer, push button, PIR or other volt free contact. Electronic timer and/or PIR if ordered is supplied separately. When using a push button the time has to be set in the control panel.

Component	Terminal	Connection	Remark
Timer 1	TMR1	31 - 32 NO - C	Can also be used for PIR
Timer 2	TMR2	33 - 34 NO - C	Can also be used for PIR

Function of aux. inputs Timer 1 (T1) and Timer 2 (T2) can be selected according to the following tables.

TIMER FUNCTION 1 (DEFAULT)

	Timer 1	Timer 2
Manual/Automatic Mode	0	0
Trickle	1	0
Normal	0	1
Boost	1	1

TIMER FUNCTION 2

	Timer 1	Timer 2
Manual/Automatic Mode	0	0
Trickle	1	0
Boost	0	1
Stop	1	1

TIMER FUNCTION 3

	Timer 1	Timer 2
Manual/Automatic Mode	0	0
Normal	1	0
Boost	0	1
Stop	1	1

TIMER FUNCTION 4

	Timer 1	Timer 2
Stop	0	0
Manual/Automatic Mode	1	0
Stop	0	1
Boost	1	1

TIMER FUNCTION 5

	Timer 1	Timer 2
Stop	0	0
Manual/Automatic Mode	1	0
Stop	0	1
Normal	1	1

6.8 FIRE PROTECTION FUNCTION

External fire alarm to stop the unit can be connected to terminals in the control box.

Smoke detectors and fire dampers cannot be connected directly to the air handling unit, a separate fire system is needed.

Component	Terminal	Connection	Remark
Fire protection function	FIRE	23 - 24 NC - C	

6.9 SUMMARY ALARM

The alarm output can be configured to indicate A-alarms or both A- and B-alarms.

Component	Terminal	Connection	Remark
Summary alarm	ALARM	21 - 22 NO - C	Voltfree contact Maximum load 24 V, 200 mA

7. WIRING DIAGRAMS

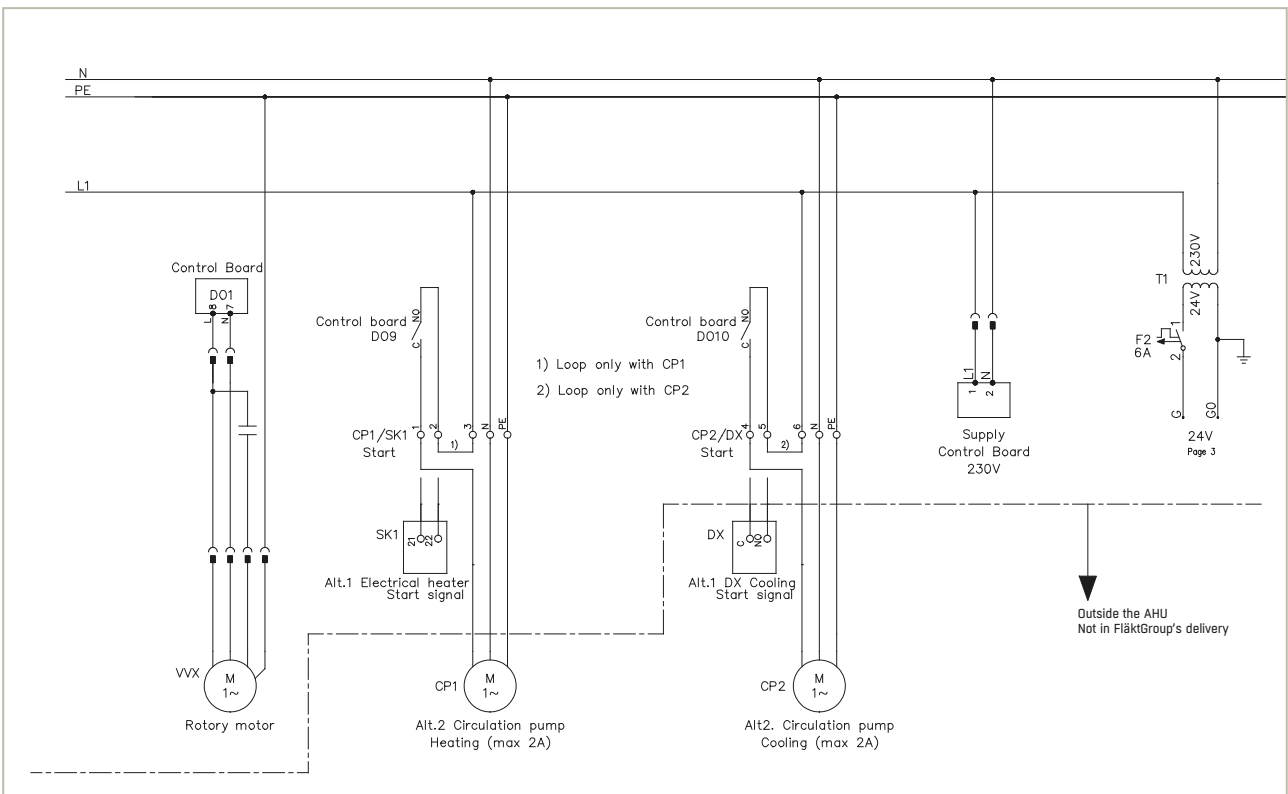
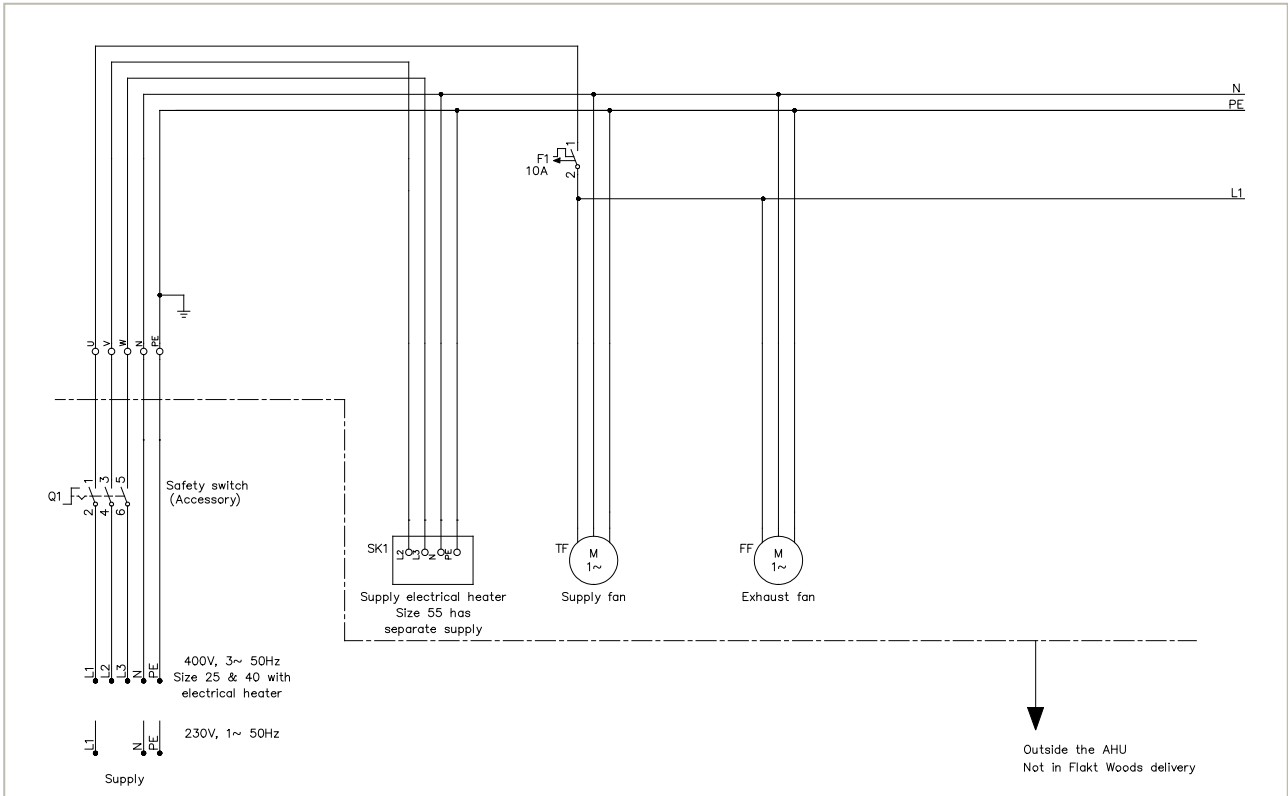

7. WIRING DIAGRAMS

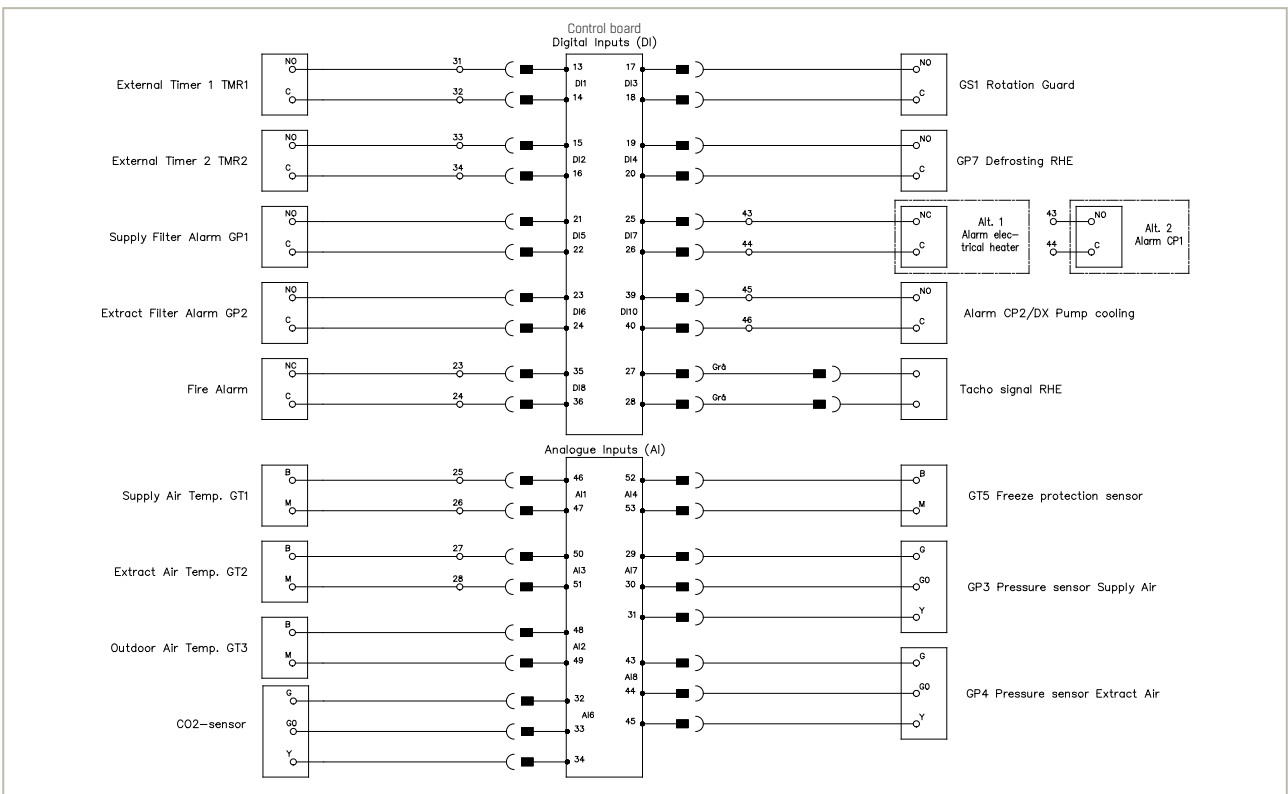
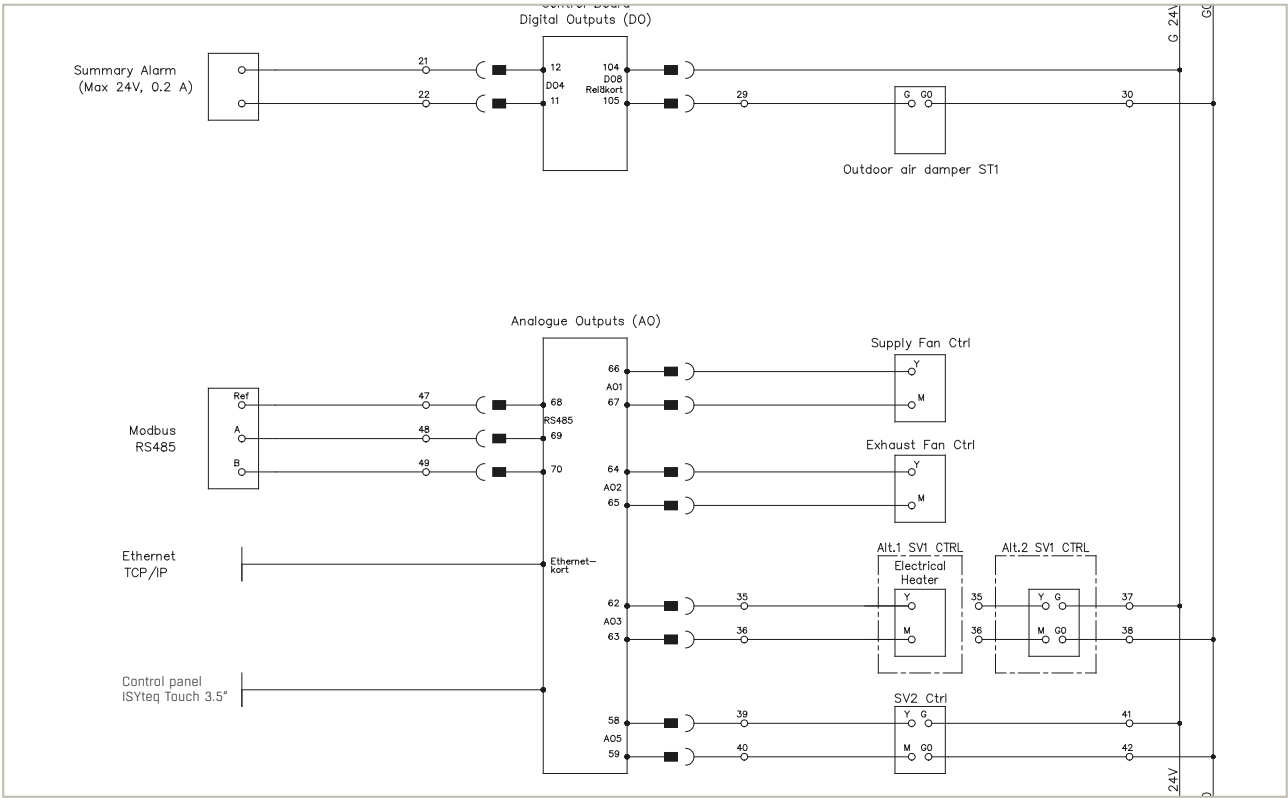

7. WIRING DIAGRAMS

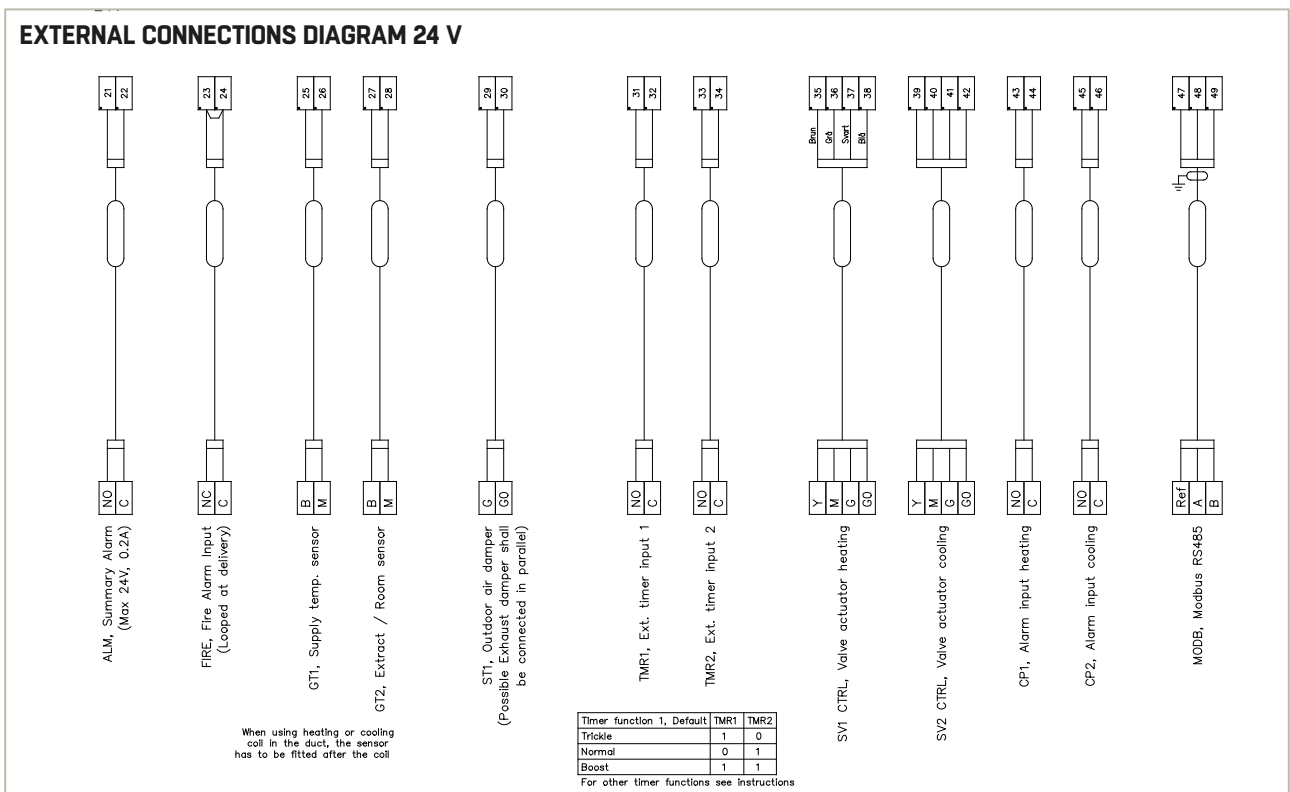
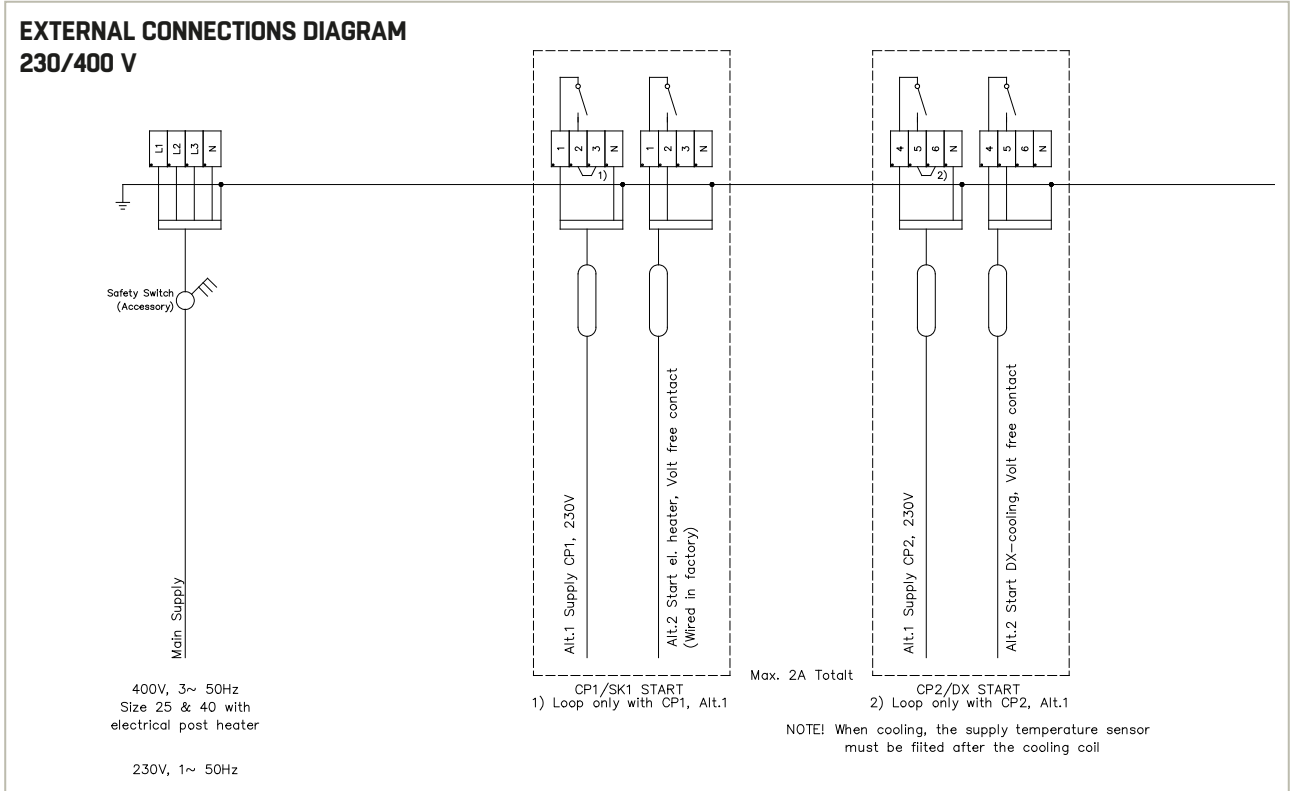

8. TESTING OF FUNCTIONS

STARTING THE UNIT

When the electrical connections are made and all the accessories are mounted the unit is ready to start up.

1. Turn the safety switch to 1 (ON).
2. Start the unit.

DAMPERS

Check that all dampers opens and closes correctly.

VALVE ACTUATORS

Check that valve actuators for heating and cooling works correctly.

DIRECTION OF ROTATION

Check that the direction of rotation for the heat exchanger corresponds to the alternatives below.

LEFT-HAND VERSION:

The rotor should rotate upwards when looking from the front.

RIGHT-HAND VERSION:

The rotor should rotate downwards when looking from the front.

AIR FLOW MEASUREMENT

The eCO TOP has measuring nipples for air flow measurement. Using a measuring pressure Δp_m (Pa) and a constant (k) the air flow q (R/W) can be calculated using the following equation:

$$q = \frac{1000}{k} \times \sqrt{\Delta p_m}$$

The value of the constant (k) is shown in the table below.

Size	03	04	06
k-value extract air fan	58,4	51,5	49,2
k-value supply air fan	62,5	52,1	51,4

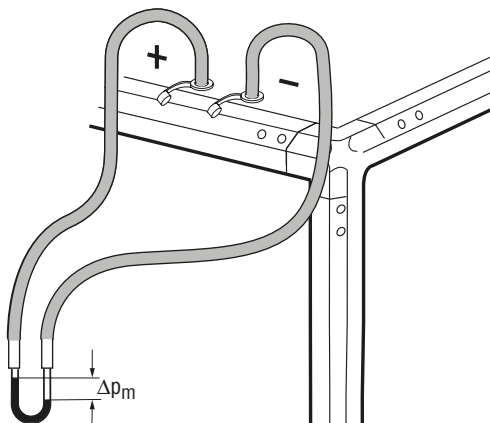

Figure 1. Location of measuring nipples on the unit.

The measuring pressure, Δp_m , is the difference between the pressure in the empty section at the fan inlet and the pressure inside the inlet cone. A manometer (RDTZ-56) can be connected to view the measuring pressure. This is used as a reference for monitoring the unit. Connect hoses with 4 mm diameter between the nipples on the top of the unit and the manometer, see Fig. 1.

If the unit is supplied with Constant Air Volume control the air flow can be read in the control panel.



NOTE! When the unit is supplied with Constant Air Volume Control there will be no measuring nipples on top of the unit.

TEMPERATURE CORRECTION

The air flow formula above applies to air with a temperature of +20° C. At other air temperatures the air flow must be corrected using the formula:

$$q = q_{20} \sqrt{\frac{(273 + t)}{293}}, \text{ m}^3/\text{s}$$

q = actual air flow

q_{20} = calculated air flow in formula above

t = current temperature in ° C

FILTER, FINAL PRESSURE DROP

It is time to replace the filters when the final pressure drop is reached, see table below.

SIZE 03

Air flow m ³ /s	0,15	0,25	0,35
Supply air/Extract air	119	148	177

SIZE 04

Air flow m ³ /s	0,30	0,40	0,50
Supply air/Extract air	125	142	159

SIZE 06

Air flow m ³ /s	0,40	0,55	0,70
Supply air/Extract air	121	139	157

FILTER MONITOR

When using filter monitors use the values in the table above. If the unit is supplied with Constant Pressure control increase the final pressure drop with 50 Pa.

9. CONTROL PANEL, OPERATIONS, COMMISSIONING

9.1 GENERAL

HMI

This section provides an introduction to the touchscreen LCD control panel, also known as the 'Human Machine Interface', or simply, HMI.

The HMI serves two main purposes: To provide information about the current operational state of the unit. To allow the unit to be setup and configured.

TOUCH SCREEN TIPS

To select an item, touch the center of the icon or option. Do not press too hard, the touch screen is sensitive enough to pick up light, firm touches. Use the tip of your finger or the back of a pencil to touch the required option. Be careful not to touch any other options.

CLEANING THE SCREEN

Disconnect the power cord. Gently wipe the screen with a soft, dry non-abrasive cloth. If the marks remain, moisten the cloth slightly with a detergent that is designed for LCD or mobile screens and wipe the screen gently from top to bottom. Never use other detergents, as these may contain ammonia or other additives.

IMPORTANT:

- Never spray, or pour liquids directly on to the screen.
- Do not clean the screen while the system is on.

CONVENTIONS USED WITHIN THIS MANUAL

The following buttons and symbols are universal and available on many menu pages.



Home key, to return to the Home Screen.



Back button, to cancel and return to the previous page.



Confirm button to confirm and proceed.



Changing a value:



Option 1: Press the arrow keys to increase or decrease the value.



Option 2: Press the displayed number to numerically adjust the value.



Use the number buttons to enter a value.

Confirm with ✓ or cancel with X.

850

Values that can only be read, but not written, are displayed without a surrounding window.

1000

Values that can be both read and written, are displayed with a surrounding window.



Some submenus has several pages. Touch the upper or the lower part of the scroll list to navigate between pages.

USING THE UNIT

POWERING ON

Each time power is applied, the unit will run through a series of internal system tests which take approximately 20 seconds to complete.

Once the internal system tests have been completed, the HMI will always display the Home screen. The unit will be in Manual Mode the first time that power is applied.

HOME SCREEN

From the Home screen it is possible to determine how the unit is operating as well as navigating to further screens to configure the unit to suit the demands of the end system.

From the Home Screen, it is possible to:





Navigate to further configuration screens to setup system parameters.

- Manually adjust the fan speed.
- Determine the operating status of the product.
- Interrogate and acknowledge system alarms.

9. CONTROL PANEL, OPERATIONS, COMMISSIONING

9.2 HOME SCREEN

STATUS LINE



-  Heat recovery active
-  Post-heater active
-  Defrosting in progress
-  Cooling active

CURRENT SET POINT VALUE

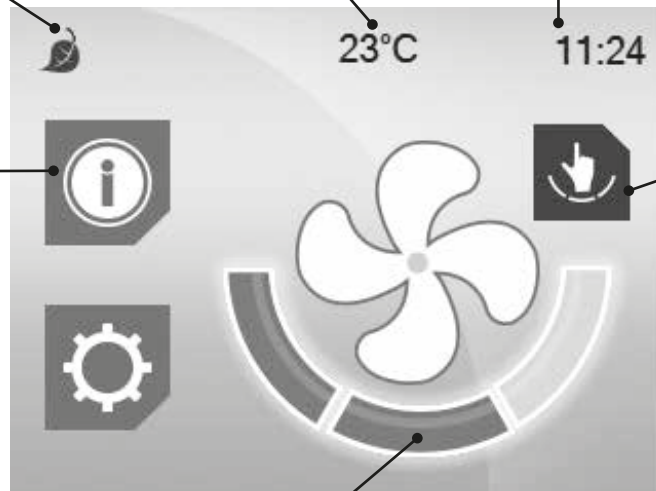









CLOCK





ALARM

-  No alarm
-  Alarm B
-  Alarm A

OPERATING STATUS

-  Manual mode
-  Automatic mode
-  COP Constant pressure
-  CAV Constant air volume
-  CO₂ CO₂ Control
-  T1 Timer 1
-  T2 Timer 2
-  T1/T2 Timer 1/Timer 2
-  Stop
-  Shut down time

OPERATING MODES

-  Trickle or low speed
-  Normal or medium speed
-  Boost or high speed

9. CONTROL PANEL, OPERATIONS, COMMISSIONING

9.2 HOME SCREEN, CONT.

SHORTCUT TO SET THE TEMPERATURE SET POINT

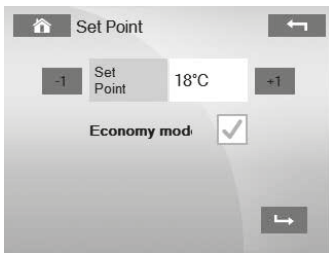

SHORTCUT TO COMMISSIONING WIZARD



SHORTCUT TO SET THE TIME AND DATE



ALARM

See section 9.3.



SELECT OPERATING MODE

See section 9.3.



STOP

MANUAL

AUTO-MATIC

USER SETTINGS

See section 9.3.

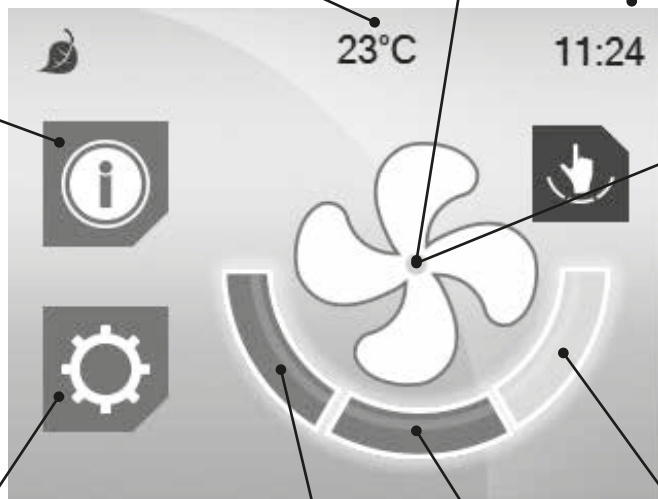
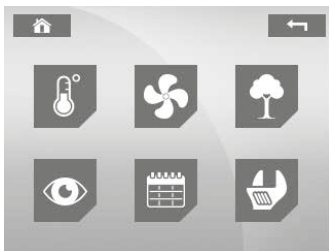

TRICKLE OR
LOW SPEED



NORMAL OR
MEDIUM SPEED



BOOST OR
HIGH SPEED

Press each field to select the operating mode.
Only active in Manual Mode.

9. CONTROL PANEL, OPERATIONS, COMMISSIONING

9.3 SUB MENUS

OPERATING MODES

The operating status icon present on the Home Screen displays the current operating mode. To change the operating mode, press the large fan icon located on the Home Screen.

The unit has three operating modes selectable through the Operating Modes screen:



Stop Mode: In this mode, the unit will stop both the supply and the extract fans.



Manual Mode: In this mode, the unit can be manually adjusted on the Home Screen to run at three different speeds.



Automatic Mode: In this mode, the unit will be automatically controlled using internal schedules and timers, CO₂ demand control, PIR sensors, etc.

ALARM SCREEN

The alarm icon on the Home Screen indicates the status of any system alarms:



No alarm



Alarm B Alarm type B are deemed non-critical and do not stop the unit ventilation.



Alarm A Alarm type A are deemed critical and will cause the unit to stop ventilating.

Press the icon to enter the Alarm Screen.

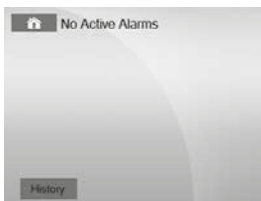

Example 1: No alarm



Example 2: Active alarms

CLEARING ALARMS

To clear an individual alarm, press the Ack button. To clear all the Alarms press the Ack All button on top of the screen.

It may not always be possible to clear the status of an alarm as the source of the alarm may immediately trigger the status to return. For example, it will not be possible to clear a faulty temperature sensor alarm until the sensor itself has been repaired or replaced.

ALARM HISTORY

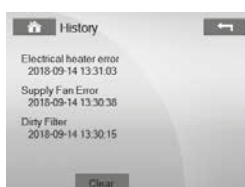

USER SETTINGS



TEMPERATURE STATUS

The temperature set point is used to determine when the post-heater (if fitted) starts to warm the supply air entering the property. The temperature set point can be adjusted to any temperature between 15° C and 35° C, factory setting is 19° C.

Temperatures and output signals are read only values.



FAN STATUS

From the Fan Status screen it will be possible to view parameters such as supply and extract fan speeds, %, off, pressures and flow rates.



AIR QUALITY

CO₂ value and CO₂ set point (if activated).



SYSTEM OVERVIEW

Version Control Panel	IP Octet 1
Bootloader Control Panel	IP Octet 2
Version Control Card	IP Octet 3
Bootloader Control Card	IP Octet 4
Unit type	



SCHEDULES

Read only. For more information see section "Schedules", section 9.7.



ADVANCED SETTINGS

See section "Advanced settings", section 9.4.

9. CONTROL PANEL, OPERATIONS, COMMISSIONING

9.4 DATE AND TIME, LANGUAGE

SETTINGS

To enter the settings menu:

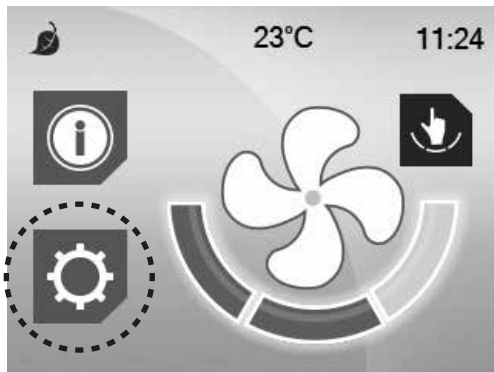

1. Push the gear cog button.



2. Push the spanner button.

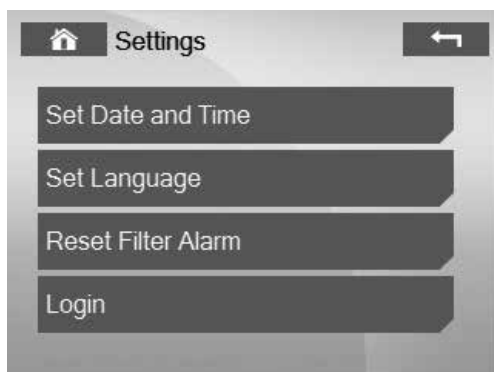

3. In this menu you set the date, time and language. It is also possible for installers and service personnel to log in and access additional parameters.

DATE/TIME

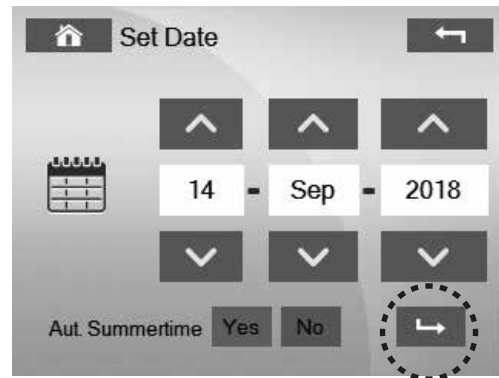

1. Set the date and press the Confirm button.

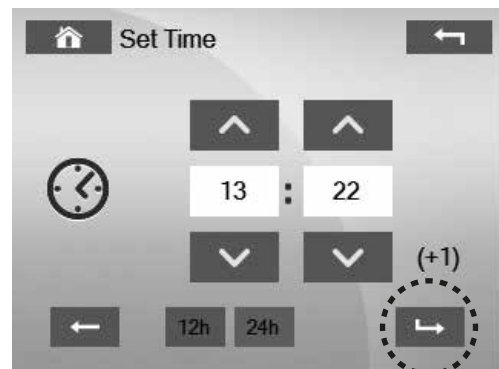

2. Set the time and press the Confirm button

CHOOSE LANGUAGE

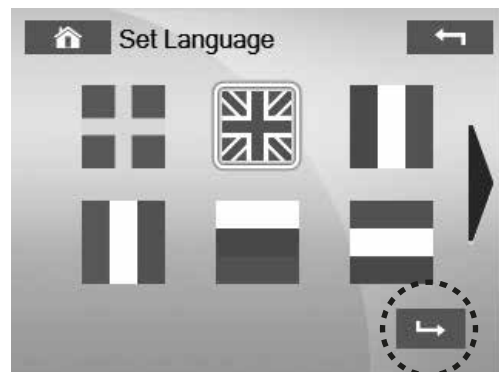

1. Choose the appropriate language flag and press the Confirm button.

Note, further language flags are available after pressing the right arrow icon. Not all translations are available.

9. CONTROL PANEL, OPERATIONS, COMMISSIONING

9.5 ADVANCED SETTINGS FOR INSTALLERS AND SERVICE PERSONNEL

This section provides an overview to the more advanced operations that are available from the Home Screen via the passcode protected Advanced Settings option.

Numerous system parameters can be adjusted through the Settings Screen; however, only those that are relevant and appropriate to the scope of the HMI User Manual will be described. It is strongly recommended to avoid the adjustment of any system parameters not outline within this section.

Access to the Settings Screen is passcode protected to prevent system critical parameters from being accidentally adjusted to values that could compromise the correct operation of the unit. Therefore, extreme caution should be observed when adjusting Advanced Settings parameters.

LOGIN

Advanced settings requires the Login passcode, **0000**, to be entered.

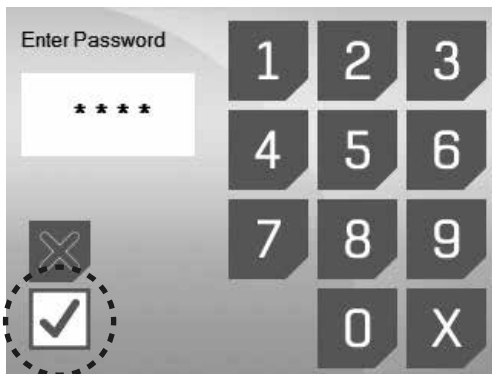

1. Enter the correct passcode and press the Confirm button.

SETTINGS FOR INSTALLERS AND SERVICE PERSONNEL

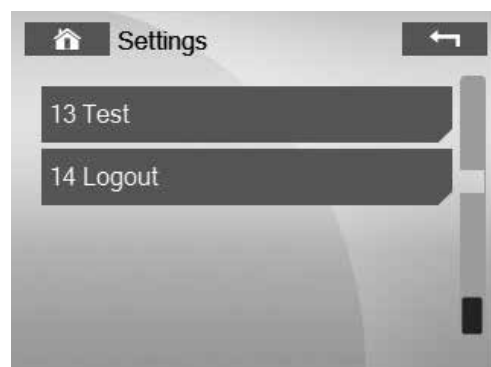
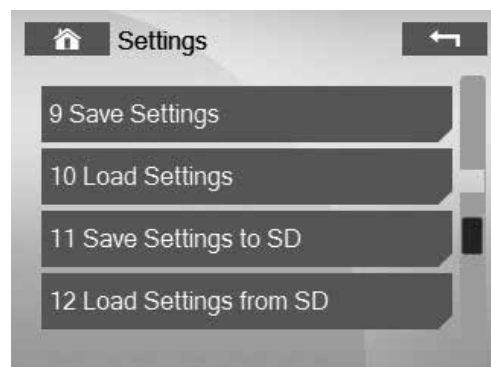
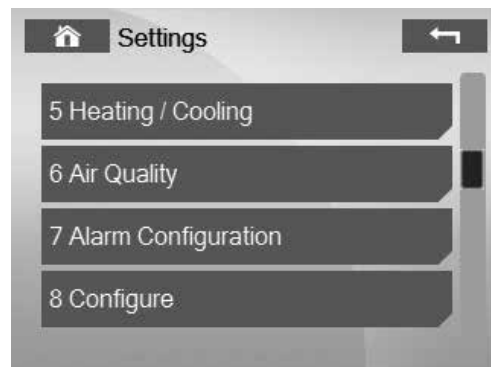

9. CONTROL PANEL, OPERATIONS, COMMISSIONING

9.6 COMMISSIONING WIZARD

There are two ways to start the wizard.

1. Press the question mark on the start screen. The question mark is not shown if the wizard has been started earlier.

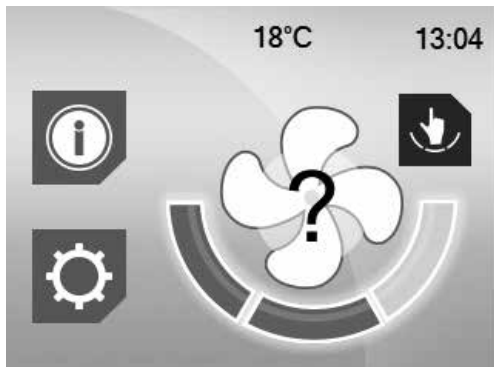

2. Choose "2. Run Commissioning Wizard" under Settings/Login



Press "2.1 Start" to get a step by step guidance through the settings needed during commissioning, or go directly to a specific menu to change a single value.



eCO Top can be ordered with four different configurations:

- 9.6.1 Standard – settings in % of max speed
- 9.6.2 Constant Air Volume – set the desired air flows
- 9.6.3 Constant pressure – set the desired pressure
- 9.6.4 CO₂ control – set the desired CO₂ level

9.6.1 STANDARD

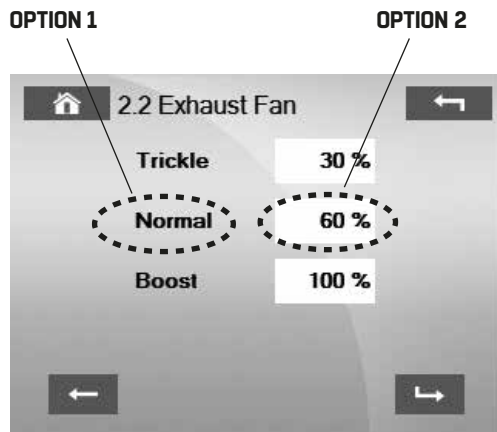
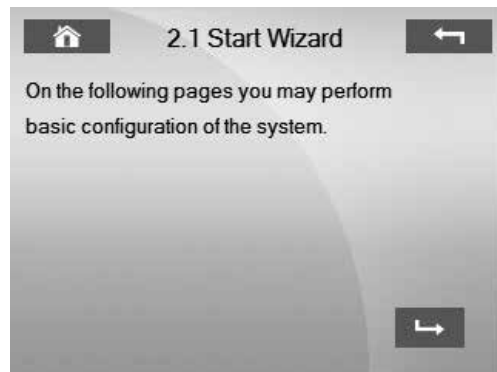

There are two ways to change the fan speeds:

- Option 1** – Press Trickle, Normal, Boost, the use ±1 or ±10 buttons
- Option 2** – Press the values within the boxes adjacent to Trickle, Normal or Boost, then use the numerical keypad.

9. CONTROL PANEL, OPERATIONS, COMMISSIONING

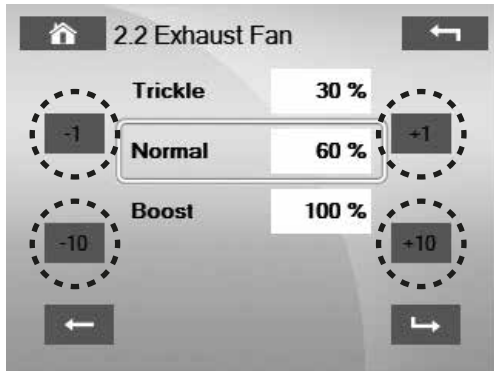

Option 1 - Use ± buttons

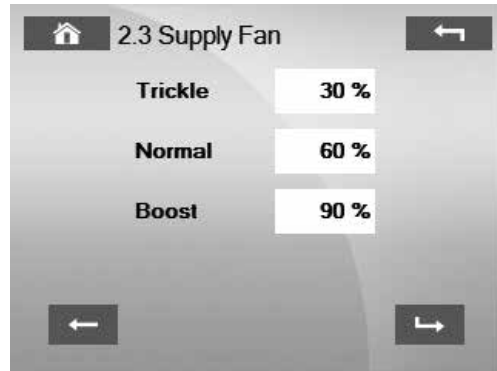

Make the appropriate settings for the supply fan and press the confirm button.



Option 2 - Use the numerical keypad, confirm with ✓.

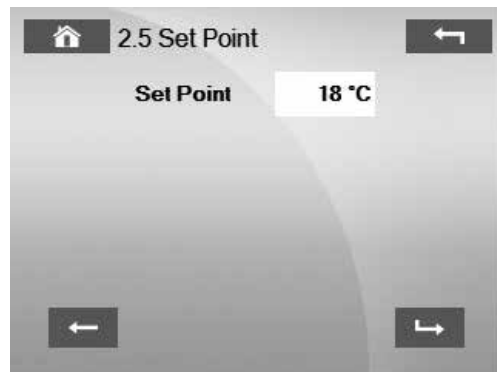

Enter desired temperature setpoint value.

If using outdoor temperature compensation, extract air control or room control also set the minimum and maximum temperature for the supply air.

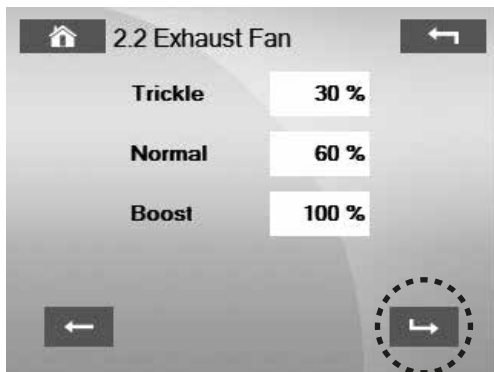

When completed, press the confirm button to proceed to next step.



9. CONTROL PANEL, OPERATIONS, COMMISSIONING

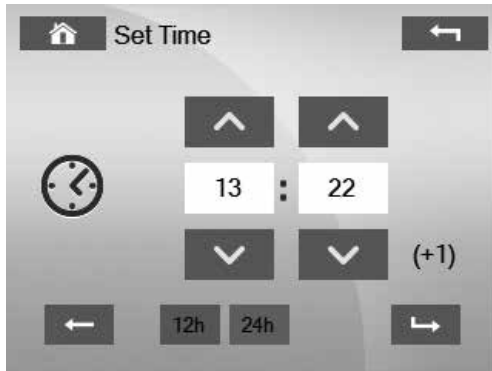

Set the air flow in R/W.

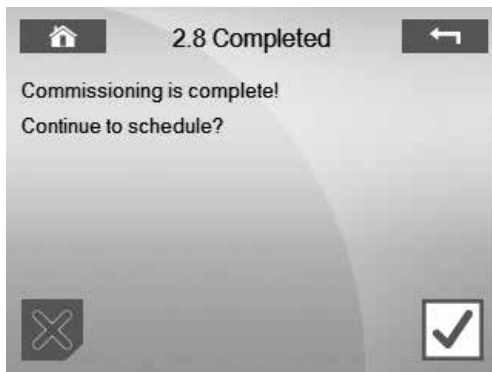

To end the commissioning wizard press the red cross button. Press the ✓ to continue to schedules. See section 9.7



For the rest of the settings see section 9.6.1.

9.6.2 CONSTANT AIR VOLUME

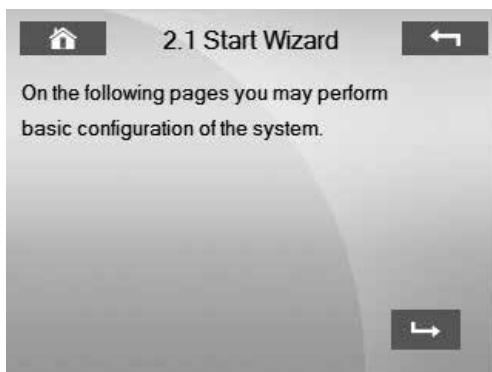

9.6.3 CONSTANT PRESSURE

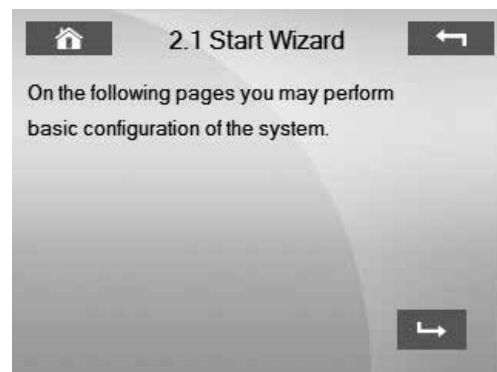

9. CONTROL PANEL, OPERATIONS, COMMISSIONING

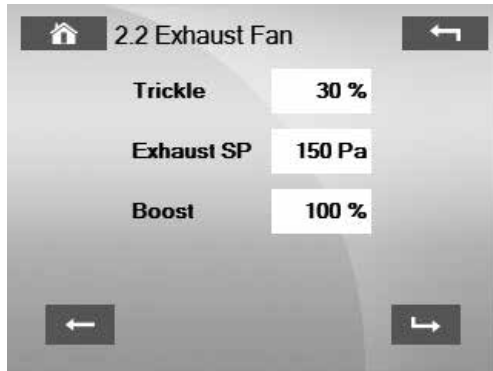

Set the desired pressure in Pa. Constant pressure control is only active in normal speed. In trickle or boost speed set the fan speed in %.

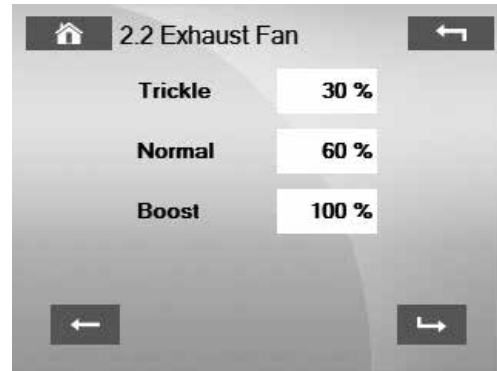

CO₂-control is only active in normal speed. In trickle or boost speed set the fan speed in %.



For the rest of the settings see section 9.6.1



9.6.4 CO₂-CONTROL

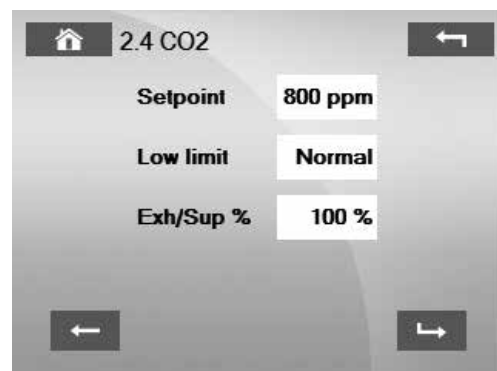
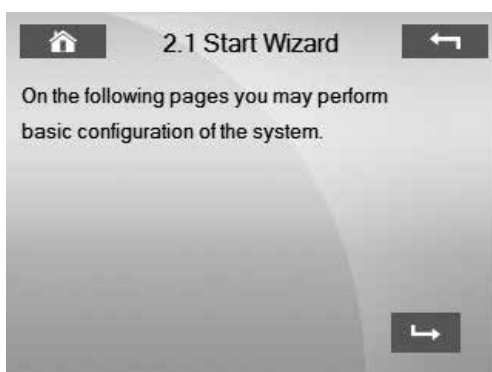

1. Set the desired CO₂-value
2. Choose CO₂ low limit. The value tells if the lower limit shall be trickle or normal speed. The speed cannot decrease under this value.
3. Set the ratio between exhaust and supply air. The exhaust fan is master and the supply fan is slave.

For the rest of the settings see section 9.6.1.

9. CONTROL PANEL, OPERATIONS, COMMISSIONING

9.7 SCHEDULES

The controller has three types of internal time schedules: Weekly, Single date and Date period.

First, program the weekly schedule with the required times. Then use any single date programs and the period to enter exceptions.

Each schedule also needs to be activated. This is done by pressing the grey tick button. A Brown tick indicates that the schedule is active.

PRIORITY

When several enabled applications overlap, the following applies:

Lowest priority	Weekly 1
-	-
-	Weekly 8
-	Single date 1
-	-
-	-
-	Single date 4
-	Date period 1
-	-
-	-
Highest priority	Date period 4

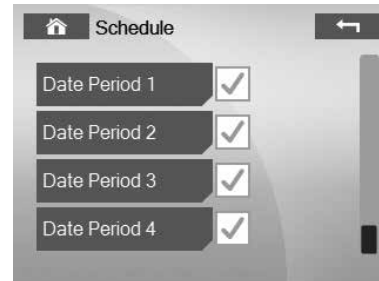

WEEKLY-SCHEDULE (1-8)

By using a weekly schedule the unit can be programmed to operate at trickle, normal and boost speed alternatively stop.

EXAMPLE 1

Below is an example of a weekly schedule configured to run the fans at normal speed from 08.00 to 18.00 Monday to Friday. At all other times, the fans are turned off.

Day	Time	Fan speed
Monday	8-18	Normal
Tuesday	8-18	Normal
Wednesday	8-18	Normal
Thursday	8-18	Normal
Friday	8-18	Normal
Other time		Stop



Only Weekly 1 should be activated.

9. CONTROL PANEL, OPERATIONS, COMMISSIONING

9.7 SCHEDULES, CONT.

EXAMPLE 2

Below is an example of a weekly schedule configured to run the fans at normal speed from 08.00 to 18.00 Monday to Thursday, from 08.00 to 17.00 on Friday and 10.00 to 14.00 on Saturday. At all other times, the fans are turned off.

Day	Time	Fan speed
Monday	8-18	Normal
Tuesday	8-18	Normal
Wednesday	8-18	Normal
Thursday	8--18	Normal
Friday	8--17	Normal
Saturday	10-14	Normal
Other time		Stop

EXAMPLE 3

Below is an example of a weekly schedule configured to run the fans at normal speed from 08.00 to 18.00 Monday to Friday.

At all other times, the fans are configured to run at trickle speed. At trickle speed the temperature set point will be decreased by two degrees.

Day	Time	Fan speed	Temperature set point
Monday	8-18	Normal	0° C
Tuesday	8-18	Normal	0° C
Wednesday	8-18	Normal	0° C
Thursday	8-18	Normal	0° C
Friday	8-18	Normal	0° C
Other time		Trickle (Low)	-2° C

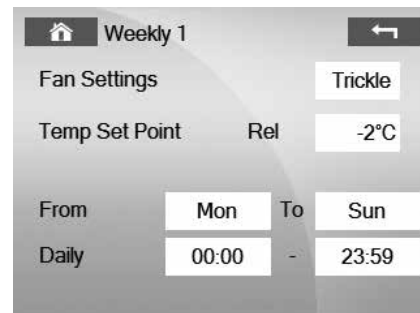

Only Weekly 1-2 should be activated.



Only Weekly 1-3 should be activated.

9. CONTROL PANEL, OPERATIONS, COMMISSIONING

9.7 SCHEDULES, CONT.

SINGLE DATE SCHEDULE (1-4)

A single date schedule is defined as a one-off schedule that automatically starts and finishes on the same date.

EXAMPLE

The unit must be switched off on 6 June.

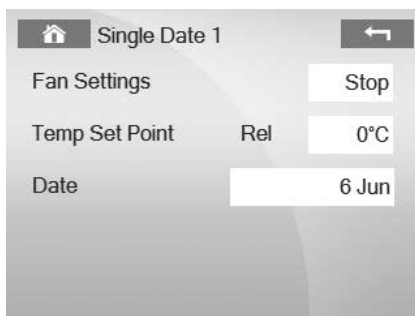

NOTE!!

Remember to enable the desired time channels by pressing



DATE PERIOD SCHEDULE (1-4)

A date period schedule is defined as a one-off schedule that is configured to run between any two dates.

EXAMPLE

The unit must be switched off between 24 December and 26 December.

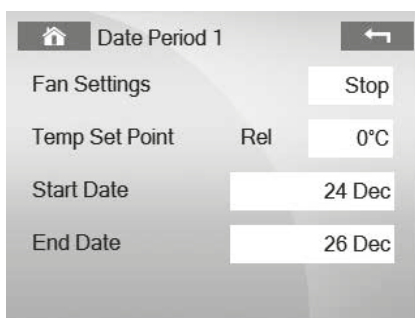

10. CONTROL FUNCTIONS

10.1 ROTOR, HEATING AND COOLING

The unit is configured differently regarding to heating, heat recovery and cooling, see below.

HEATING

- No heater
- Electrical post heater
- Hot water coil

HEAT RECOVERY

- Step less rotary heat exchanger

COOLING

- No cooling
- Water
- DX, On/Off

CONTROL FUNCTION

The control function works as follows:

Regardless of control mode the unit tries to achieve the desired setpoint.

This is done by the unit depending on the needs, demand for heat recovery, heating or cooling. Built into the system is also a dead zone. The dead zone function (usually 2°C) acts as a temperature zone between heat recovery and cooling where neither calls for heat recovery or cooling.

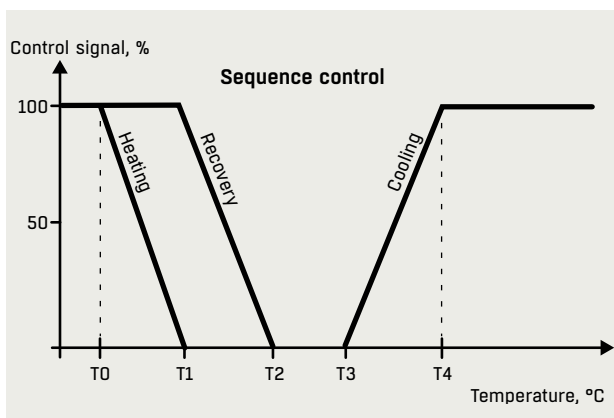

Figure 1. The figure shows the controller's output signals to the various components at different temperatures. The figure also shows two temperatures, one for heating (T2) and one for cooling (T3). The zone between T2 and T3 is called the dead zone. Note that heating is activated only when heat recovery is working at 100%.

10.2 TEMPERATURE CONTROLS

eCO TOP has three temperature control options, supply air, extract air and room.

Room control and extract air control is the same control type with the difference that in combination with room control an external room sensor is needed (separate ordering code). In addition it is possible to use outdoor temperature compensation. This control mode cannot be combined with extract air control or room control.

The unit is configured for supply air control as standard. To obtain other control modes, first the controller must be changed from standard mode to cascade mode. Then control mode is selected by changing the cascade reference to extract air control/room control (0) or outdoor temperature compensation (1). Below is a description of the different control modes.

SUPPLY AIR CONTROL

To maintain a constant supply air temperature, the controller works with the setpoint and the supply air temperature. Based on these parameters, the current heating, heat recovery and cooling sequences are controlled.

EXTRACT AIR CONTROL

The extract air temperature gives a good average value of the temperature in different rooms. Using this the unit controls the supply air temperature to maintain the extract temperature at a desired level.

This method is suitable for ventilation systems that supply a number of similar rooms. In cases where different rooms have different heating requirements, this method should not be used. This is because the unit cannot detect the varying heating needs, but can only read an average temperature.

The limits on the supply air temperature (min. temp. / max. temp.) ensure that the supply air temperature is maintained within the set range.

DEFAULT PARAMETERS FOR EXTRACT AIR CONTROL

- | | |
|--------------------------|---|
| 1. Controller = 2 | Selects cascade control |
| 2. Cascade reference = 0 | Selects extract air control |
| 3. Cascade A = 0.5 | When the sensor gets colder than given setpoint value |
| 4. Cascade B = -0.5 | When the sensor gets warmer than given setpoint value |
| 5. Min. temp. = 15°C | Sets lowest supply air temperature |
| 6. Max. temp. = 25°C | Sets highest supply air temperature |

10. CONTROL FUNCTIONS

EXAMPLE

1. Setpoint = 18°C
2. Extract air temperature = 16°C

This means that the new calculated setpoint for the supply air controller is:

Calculated setpoint = setpoint + (setpoint – extract air temperature) x cascade A = 18 + (18-16) x 0.5 = 19 ° C.

ROOM CONTROL

Room control gives the best control of temperature in a specific room and is used when only one unit serves this room. This method works best for larger premises.

By replacing the extract temperature sensor with a temperature sensor placed in the room a good room temperature value is achieved.

This enables the unit to regulate the supply air temperature in a way that maintains the room temperature at a desired level.

Limitation of the supply air temperature (min. temp. and max. temp.) ensures that the supply air temperature is maintained within the set range.

DEFAULT PARAMETERS FOR ROOM CONTROL

1. Controller = 2 Selects cascade control
2. Cascade reference = 0 Selects room control
3. Cascade A = 0.5 When the sensor gets colder than given setpoint value
4. Cascade B = -0.5 When the sensor gets warmer than given setpoint value
5. Min. temp. = 15°C Sets lowest supply air temperature
6. Max. temp. = 25°C Sets highest supply air temperature

EXAMPLE

1. Setpoint = 18°C
2. Room temperature = 22°

This means that the new calculated setpoint for the supply air controller is:

Calculated setpoint = setpoint + (setpoint – room air temperature) x cascade B = 18 – (18 – 22) x (-0.5) = 16°C.

OUTDOOR TEMPERATURE COMPENSATION

The setpoint temperature for supply air can be adjusted up or down depending on the outdoor temperature. By setting a higher set point value both on cold winter days and hot summer days indoors comfort is improved.

In summer, this will increase energy savings. Outdoor temperature compensation can not be combined with extract air control or room control.

DEFAULT PARAMETERS FOR OUTDOOR TEMPERATURE COMPENSATION

1. Controller = 2 Selects cascade control.
2. Cascade reference = 1 Selects outdoor temperature compensation.
3. Cascade A = 0,05 When the sensor gets colder than given setpoint value.
4. Cascade B = 0.03 When the sensor gets warmer than given setpoint value.
5. Min. temp. = 15°C Sets lowest supply air temperature.
6. Max. temp. = 25°C Sets highest supply air temperature.

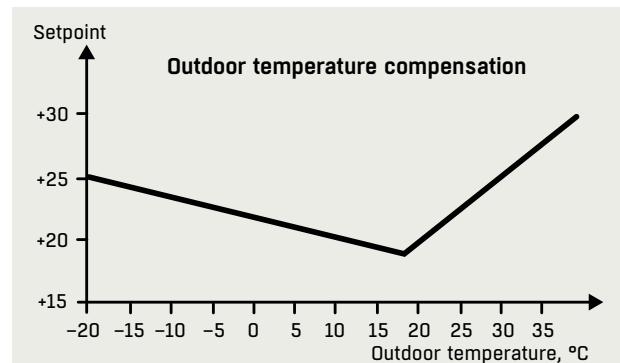

EXAMPLE 1

1. Setpoint = 18°C
2. Outdoor air temperature = -2°C

This means that the new calculated setpoint for the supply air controller is:

Calculated setpoint = setpoint + (setpoint – outdoor air temperature) x cascade A = 18 + (18 – (-2)) x 0.05 = 19°C

EXAMPLE 2

1. Setpoint = 18°C
2. Outdoor air temperature = 28°C

This means that the new calculated setpoint for the supply air controller is:

Calculated setpoint = setpoint + (setpoint – outdoor air temperature) x cascade B = 18 – (18 – 28) x 0.30 = 21°C.

10. CONTROL FUNCTIONS

10.3 FREEZE PROTECTION

Warning! Do not change these parameters unless it is absolutely necessary. If the unit is misconfigured the water coil can freeze up and cause water damage to property.

Freeze protection is used during low outdoor temperatures to prevent the coil from freezing. When the unit is stopped, the temperature in the water coil is maintained at the setpoint to keep the unit warm. If there is a risk of freezing in the water coil the valve is controlled to open.

If the temperature drops below the limit value an A-alarm is obtained, which then stops the unit.

10.4 DEFROST FUNCTION

The defrost function is used to prevent the rotor from freezing. By measuring the pressure across the rotor it is possible to verify when the rotor needs to be defrosted.

When the pressure over the rotor becomes too high it activates a time delay before defrosting. Then defrosting starts. When the pressure is below the given limit value it starts a time delay. When the time delay has elapsed, the defrosting stops.

Defrosting is achieved by running the rotor section-wise. Fan speeds are not affected.

Size	Rotor thermal efficiency	
	80% (Pa)	85% (Pa)
03	240	270
04	240	300
06	260	300

10.5 COOLING RECOVERY

In summer, when the extract air temperature is more than 2°C colder than the outdoor air temperature, the rotary heat exchanger will start for cooling recovery.

10.6 NIGHT COOLING

Night cooling is used in summertime to reduce cooling load at unit start-up and to limit the maximum temperature during non-working hours. This is done by making use of cold outside air during cool summer nights.

Parameters	Value (exemple)	Comment
Night cooling activated	Yes	Activated night cooling
Room setpoint	22°C	Room setpoint night cooling
Delta	5°C	Min difference room temp.
Hysteresis	2°C	Hysteresis for night cooling
Test time, start	kl. 22.0	Start time for night cooling test
Test time, off	kl.22.15	Stop time for night cooling test
Max time	540 minutes	Maximal activation time for night cooling

STARTING CONDITIONS

- Night cooling activated
- Auto mode enabled
- The unit is in the stop position as scheduled

TEST PERIOD AND EVALUATION

- The unit is started at 22.00 and then operates at normal speed
- At 22.15 it is determined whether night cooling is needed or not. The following conditions must be met:
 - The unit is in "Summer mode" .
 - Outdoor temperature < Extract temperature – Delta.
 - Extract temperature > Room setpoint + Hysteresis.
- If the above conditions are met the night cooling starts.

THE FOLLOWING TAKE PLACE DURING NIGHT COOLING

- Rotor, postheater and any cooling are blocked.
- The fans are switched to the high speed setting.

NIGHT COOLING TAKES PLACE AS LONG AS THE FOLLOWING CONDITIONS ARE FULFILLED:

- Unit is in "Summer mode".
- Outdoor temperature < Extract temperature – Delta.
- Extract temperature > Room setpoint.
- Function maximum activation time is not reached.

10. CONTROL FUNCTIONS, CONT.

10.7 FAN CONTROL

10.7.1 STANDARD

3-speed control (trickle, normal, boost). To change fan speed use schedules, external timer or PIR.

10.7.2 CONSTANT PRESSURE CONTROL (COP)

Control principle in which the unit maintains a constant duct pressure. Normally used in variable flow systems (VAV).

Pressure sensors GP3 and GP4 are mounted in the control box. With pressure control the pressure in the index duct (the duct with the highest pressure and where the static pressure is the lowest) is controlled. The hose from the pressure sensor GP3 has to be placed in the supply air duct and the hose from the pressure sensor GP4 has to be placed in the extract air duct. Make sure that both the hoses have to be placed at a suitable location with a representative pressure.

Units that are supplied with pressure control will be pre-configured for that. For settings see section 9.6.

10.7.3 CONSTANT AIR VOLUME (CAV)

Control principle in which the unit maintains a constant duct flow. Pressure sensors are mounted in the control box and all the hoses are connected.

Using a measurement pressure Δp_m in Pa and a constant k , the airflow q in R/W is calculated with the following formula:

$$q = \frac{1000}{k} \times \sqrt{\Delta p_m}$$

The measuring pressure, Δp_m , is the difference between the pressure in the empty section at the fan inlet and the pressure inside the inlet cone.

Value of the constant (k) is shown in the table below. For settings see section 9.6.

Size	03	04	06
k-value extract air fan	58,4	51,5	49,2
k-value supply air fan	62,5	52,1	51,4

ZERO POINT-CALIBRATION, PRESSURE SENSORS

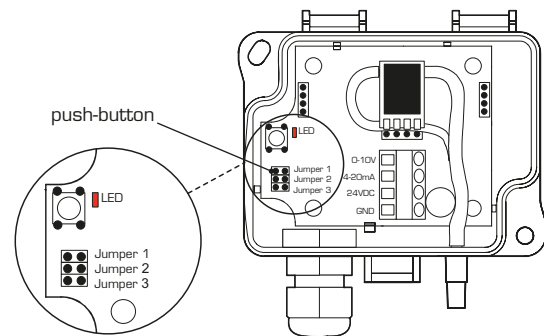

The sensors must be zeroed during commissioning. They should then be zeroed annually. The sensors should have been energized for approximately one hour before calibration is carried out. After that, remove the hoses from the sensors. To start calibration press the push-button next to the pressure range jumpers.

The red LED lights up and goes out after about a second.

Reassemble the air hoses. **Done!**

10.7.4 CO₂ CONTROL

Control principle in which the unit limits the CO₂ value.

A CO₂ sensor is mounted in the extract air when delivered.

11. COMMUNICATION

The unit can communicate with a Building Management System (BMS) via Modbus (RS485 and TCP/IP). No other protocols are supported.

11.1 MODBUS, RS485

See table below for connection of Modbus. For more information, see the separate Modbus ins

Component	Terminal	Connection	Note
Modbus, RS485	Modbus	47 - 48 - 49 REF - A - B	

11.2 MODBUS, TCP/IP

The unit has a built-in Ethernet card for connection to a LAN. Connect the Ethernet cable (RJ45) to the connector on top of the unit.

11.3 WEBSERVER

There is a built-in webserver in the ISYteq Mini control system. This makes it possible to read and change parameters via a web browser.

The screenshot shows a web browser interface for configuring the IP address. At the top, there is a home icon, the title '8.1 IP Address', and a back arrow. Below the title, there is a label 'Static/Dynamic IP Address' and a button labeled 'Dynamic'. The main content is a table with three rows: 'IP Address', 'Subnet', and 'Gateway'. Each row has four input fields. The 'IP Address' row contains the values 10, 206, 20, and 89. The 'Subnet' row contains 255, 255, 255, and 0. The 'Gateway' row contains 10, 206, 20, and 254. At the bottom right, there is a forward arrow button.

Static/Dynamic IP Address	Dynamic			
IP Address	10	206	20	89
Subnet	255	255	255	0
Gateway	10	206	20	254

To read or change the IP-address, enter menu 8.1.

12. PARAMETER LIST

Incorrect parameter settings may cause malfunction and freezing damage in hot water coil. Therefore all settings has to be made by persons with necessary knowledge.



TEMPERATURE STATUS

Parameter	Type of value ¹⁾	Range	Unit	Default value	Comments
Supply air	R	-40-100	° C	-	
Outdoor air	R	-40-100	° C	-	
Extract air	R	-40-100	° C	-	
Freeze protection	R	-40-100	° C	-	For unit with Hot Water Coil
Set point	R/W	15-35	° C	19	
Summer / Winter mode	R	Summer / Winter	-	-	
Output signal, Post Heater	R	0-100	%	-	
Output signal, Pre Heater	R	0-100	%	-	Not för eCO Top
Output signal, Heat Recovery	R	0-100	%	-	
Output signal, Cooling	R	0-100	%	-	
Control mode/Calculated Set point	R	15-35	° C	-	



FAN STATUS

Parameter	Type of value ¹⁾	Range	Unit	Default value	Comments
Supply Fan, speed	R	0 or 15-100	%	-	
Exhaust Fan, speed	R	0 or 15-100	%	-	
Pressure Supply air	R	0-2000	Pa	-	For unit with COP
Pressure Exhaust air	R	0-2000	Pa	-	For unit with COP
Supply air set point	R	0-2000	Pa	-	For unit with COP
Exhaust air set point	R	0-2000	Pa	-	For unit with COP
Air flow, Supply air	R	0-9999	l/s	-	For unit with CAV
Air flow, Exhaust air	R	0-9999	l/s	-	For unit with CAV
Supply air flow, Set point	R	0-9999	l/s	-	For unit with CAV
Exhaust air flow, Set point	R	0-9999	l/s	-	For unit with CAV



AIR QUALITY

Parameter	Type of value ¹⁾	Range	Unit	Default value	Comments
CO ₂ value	R	0-2000	ppm	-	Actual CO ₂ value in extract air
CO ₂ Set point	R	0-2000	ppm	800	



SYSTEM OVERWIEV

Parameter	Type of value ¹⁾	Range	Unit	Default value	Comments
Software version, Control panel	R	-	-	-	
Bootloader version, Control panel	R	-	-	-	
Software version, Control board	R	-	-	-	
Bootloader version, Control board	R	-	-	-	
Unit type	R	-	-	eCO Top	
IP Octet 1	R	0-255	-	-	Actual IP-address, accessory
IP Octet 2	R	0-255	-	-	
IP Octet 3	R	0-255	-	-	
IP Octet 4	R	0-255	-	-	

¹⁾ R/W = Read and write value, R = Read only value

12. PARAMETER LIST



SCHEDULES

Parameter	Type of value ¹⁾	Range	Unit	Default value	Comments
Schedules	R	-	-	-	Active schedules, read only



SETTINGS

Parameter	Type of value ¹⁾	Range	Unit	Default value	Comments
Set Date and Time	R/W	-	-	-	
Set Language	R/W	-	-	Swedish	
Login	R/W	0000-9999	-	0000	For installers and Service personnel
Settings					Not för eCO Top
1. Schedule					See section 9.7.
2. Commissioning Wizard					See section 9.6.
3. Timer Control					
Timer control	R/W	1-6	-	1	See section 6.7
Timer Release Delay	R/W	0-9999	min	0	
4. Fan Control					
4.1 Fan settings					
Boost Running Timer	R/W	Yes / No	-	No	
Boost Running Time	R/W	0-9999	min	120	
Startup Time	R/W	0-32767	s	15	Extract Fan starts directly, Supply Fan after selected time
Shut Down Time	R/W	0-32767	s	0	180 sec for unit with Electrical heater
Fireplace	R/W	0-360	min	30	Not för eCO Top
4.2 COP / CAV					Constant pressure / Constant air volume. For units ordered with Pressure sensors
Pressure Control Supply air	R/W	Yes/No		Yes	For unit with COP
Pressure Control Extract air	R/W	Yes/No		Yes	For unit with COP
Supply air pressure Set point	R/W	0-2000	Pa	150	
Extract air pressure Set point	R/W	0-2000	Pa	150	
Airflow Control Supply air	R/W	Yes/No		Yes	For unit with CAV
Airflow Control Extract air	R/W	Yes/No		Yes	For unit with CAV
Only Supply, Extract as slave	R/W	Yes/No		No	
Ratio Supply/Extract	R/W	0-200	%	100	
Supply, Trickle Airflow, size 04	R/W	0-9999	R/W	300	150 for size 03, 400 for size 06
Supply, Normal Airflow, size 04	R/W	0-9999	R/W	400	250 for size 03, 550 for size 06
Supply, Boost Airflow, size 04	R/W	0-9999	R/W	500	350 for size 03, 700 for size 06
Extract, Trickle Airflow, size 04	R/W	0-9999	R/W	300	150 for size 03, 400 for size 06
Extract, Normal Airflow, size 04	R/W	0-9999	R/W	400	250 for size 03, 550 for size 06
Extract, Boost Airflow, size 04	R/W	0-9999	R/W	500	350 for size 03, 700 for size w

¹⁾ R/W = Read and write value, R = Read only value

12. PARAMETER LIST

Parameter	Type of value ¹⁾	Range	Unit	Default value	Comments
5. Heating / Cooling					
5.1 Pre Heater					
					Not for eCO Top
5.2 Heating/Cooling					
Temperature control option	R/W	1-2		1	1 = Standard, supply air control. See section 10.2 2 = Cascade control See section 10.2
Minimum Supply temp	R/W	15-35	° C	15	
Maximum Supply temp	R/W	15-35	° C	25	
Cooling sequence	R/W	Yes/No		No	
Cooling DX	R/W	Yes/No		No	
Dead zone Cooling	R/W	Yes/No		Yes	
Dead zone	R/W	0-25	° C	2	
Block cooling in Winter	R/W	Yes/No		Yes	
Block heating in Summer	R/W	Yes/No		Yes	
Post Heater	R/W	Yes/No		Yes	
Cascade reference	R/W	0-1		0	0 = Extract air control 1 = Outdoor air compensation
Cascade A	R/W	-10-10	° C	0,5	
Cascade B	R/W	-10-10	° C	-0,5	
Relative / Absolute temperature	R/W	rel/abs		rel	Relative or absolute temperatures in Schedule
5.3 Night Cooling					
Night Cooling	R/W	Yes/No		No	See section 10.6 Choose YES to activate Night Cooling
Room Set point	R/W	15-50	° C	20	
Test period start	R/W	19:00-04:00	time	22:00	
Test preiod stop	R/W	19:00-04:00	time	22:15	
Delta	R/W	0-20	° C	5	
Hysteresis	R/W	0-20	° C	2	
Maximum running time	R/W	1-720	min	540	
5.4 Defrosting					
					See section 10.4
5.5 Cooling Recovery					
Cooling Recovery	R/W	Yes / No	-	Yes	See section 10.5
Temperature difference (outdoor-extract)	R/W	0-15	° C	2	
5.6 Summer / Winter mode					
Current season mode	R	Summer / Winter	-	-	
Automatic/Manual mode	R/W	Auto / Manuell	-	Auto	
Manual Summer / Winter mode	R/W	Summer / Winter	-	Winter	
5.7 Frost protection					
Pump stop	R/W	Yes/No	-	Yes	See section 10.3 No = Pumps always running
Pump Stop mode	R/W	Summer / Winter Heating / Cooling		Heating / Cooling	Heating/Cooling = Heating pump is running when there is a heating demand. Cooling pump is running when there is a cooling demand. Summer/Winter = Heating pump is running when the unit is in winter mode. Cooling pump is running when the unit is in summer mode. Exercise of pumps every day at 12.00-12.05.
Constant temp Hot Water Coil	R/W	0-50	° C	25	
Low limit running temp, Set point	R/W	0-50	° C	12	
Frost Protection Alarm, Set Point	R/W	0-50	° C	7	

¹⁾ R/W = Read and write value, R = Read only value

12. PARAMETER LIST

Parameter	Type of value ¹⁾	Range	Unit	Default value	Comments
6. Air quality					
6.1 CO₂ Control					
CO ₂	R/W	Yes/No	-	No	
CO ₂ Set point	R/W	0-2000	ppm	800	
P-band	R/W	0-2000	ppm	800	
I-time	R/W	0-9999	s	600	
ppm at 0V	R/W	0-9999	ppm	0	
ppm at 10V	R/W	0-9999	ppm	2000	
CO ₂ Low Limit	R/W	Trickle/Normal	-	Normal	
6.2 Moisture Control					
					Not for eCO Top
7. Alarm Configuration					
7.1 Alarm Settings					
Dirty Filter alarm time	R/W	0-600	days	0	Set to 0 to deactivate the filter alarm
A and B on first Relay	R/W	Yes / No	-	Yes	
Enable temperature alarm	R/W	Yes / No	-	Yes	
Temperature alarm	R/W	-10 - +10	° C	5	
Activate test of RHE belt	R/W	Yes / No	-	No	Not for eCO Top
7.2 Alarm categories					
Fire Alarm	R/W	A/B	-	A	External function
Sensor Error Supply air	R/W	A/B	-	A	
Sensor Error Outdoor air	R/W	A/B	-	A	
Sensor Error Extract air	R/W	A/B	-	A	
Sensor Error Frost Protection	R/W	A/B	-	A	For unit with Hot Water coil
Sensor Error Defrost	R/W	A/B	-	B	Not for eCO Top
Sensor Error AI10	R/W	A/B	-	B	Not for eCO Top
Supply Fan Error	R/W	A/B	-	A	
Extract Fan Error	R/W	A/B	-	A	
Dirty Filter Alarm	R/W	A/B	-	B	Not for eCO Top
Pressure switch RHE	R/W	A/B	-	B	
RHE Failure	R/W	A/B	-	B	
Filter Alarm Supply	R/W	A/B	-	B	
Filter Alarm Extract	R/W	A/B	-	B	
Electrical Heater Error	R/W	A/B	-	B	
Pump Heater Malfunction	R/W	A/B	-	B	
Frost Protection	R/W	A/B	-	B	
Alarm Cooling	R/W	A/B	-	B	
Pump Cooling Malfunction	R/W	A/B	-	B	
Temperature alarm	R/W	A/B	-	A	
RHE belt alarm	R/W	A/B	-	A	Not for eCO Top
7.3 Alarm Delays					
Fire Alarm	R/W	0-9999	s	2	External function
Sensor Error Supply air	R/W	0-9999	s	5	
Sensor Error Outdoor air	R/W	0-9999	s	5	
Sensor Error Extrac air	R/W	0-9999	s	5	
Sensor Error Frost Protection	R/W	0-9999	s	5	For unit with Hot Water coil
Sensor Error Defrost	R/W	0-9999	s	5	Not for eCO Top
Sensor Error AI10	R/W	0-9999	s	5	Not for eCO Top
Supply Fan Error	R/W	0-9999	s	2	
Extract Fan Error	R/W	0-9999	s	2	
RHE Failure	R/W	0-9999	s	2	
Filter Alarm Supply air	R/W	0-9999	s	60	
Filter Alarm Extract air	R/W	0-9999	s	60	
Electrical Heater Error	R/W	0-9999	s	2	
Pump Heater Malfunction	R/W	0-9999	s	2	
Frost Protection	R/W	0-9999	s	2	
Alarm Cooling	R/W	0-9999	s	2	
Pump Cooling Malfunction	R/W	0-9999	s	2	
Temperature alarm	R/W	0-9999	min	10	
RHE Belt Alarm	R/W	0-9999	s	60	Not for eCO Top

¹⁾ R/W = Read and write value, R = Read only value

12. PARAMETER LIST

Parameter	Type of value ¹⁾	Range	Unit	Default value	Comments
7.4 Contact function					
DI1 Timer 1	R/W	NO/NC	–	NO	
DI2 Timer 2	R/W	NO/NC	–	NO	
DI3 RHE Rotation Guard	R/W	NO/NC	–	NO	
DI4 Defrost pressure switch	R/W	NO/NC	–	NO	
DI5 Filter Alarm Supply air	R/W	NO/NC	–	NO	
DI6 Filter Alarm Extract air	R/W	NO/NC	–	NO	
DI8 Fire Alarm	R/W	NO/NC	–	NC	
DI9 Cooker Hood	R/W	NO/NC	–	NO	Not for eCO Top
DI7 Alarm Heater	R/W	NO/NC	–	NO	NC with Electrical Heater
DI10 Alarm cooling	R/W	NO/NC	–	NO	
8. Configure					
8.1 IP Address	R/W	Static / Dynam	–	Dynamic	Static = Manual Dynamic = Automatic via DHCP
Subnet mask	R/W	–	–	–	
Gateway	R/W	–	–	–	
8.2 Menu configure					
Log to USB	R/W	Yes / No	–	No	Only for troubleshooting
Unit Type	R	–	–	eCO Top	
Auto logout time	R/W	0-32767	min	10	
Threshold Heater	R/W	0-100	%	0	For Installers and Service Personnel
Threshold Cooling	R/W	0-100	%	0	For Installers and Service Personnel
Threshold Heat Exchanger	R/W	0-100	%	0	For Installers and Service Personnel
Threshold External Fan	R/W	0-100	%	5	For Installers and Service Personnel
8.3 Screen saver					
Screensaver	R/W	On/Off	–	On	
Timeout	R/W	–	min	10	
8.4 Modbus BMS					
Modbus Slave Address	R/W	0-255	–	2	
Baudrate	R/W	9.6, 19.2, 38.4	–	19,2	
Parity	R/W	None, Even, Odd	–	None	
Data bits	R/W	7,8	–	8	
Stop bits	R/W	1,2	–	1	
8.5 Mac address					
Mac address	R	–	–	–	
8.6 Reset					
8.6.1 Soft reset					
Reset	–	–	–	–	All values are reset except adjusted air flows and setpoints
8.6.2 Factory reset					
Reset	–	–	–	–	All values are reset
8.7 Login settings					
Auto Logout	R/W	Yes/No	–	Yes	
Set Password 1	R/W	–	–	–	To change password
8.8 About					
Software Version Control Panel	R	–	–	–	
Software Version Control Board	R	–	–	–	
Bootloader version Control Board	R	–	–	–	

¹⁾ R/W = Read and write value, R = Read only value

12. PARAMETER LIST

Parameter	Type of value ¹⁾	Range	Unit	Default value	Comments
9. Save settings					Saves adjusted values
Slot 1	-	-	-	-	
Slot 2	-	-	-	-	
Slot 3	-	-	-	-	
Slot 4	-	-	-	-	
Slot 5	-	-	-	-	
10. Load settings					Upload saved adjusted values from Control Panel
Slot 1	-	-	-	-	
Slot 2	-	-	-	-	
Slot 3	-	-	-	-	
Slot 4	-	-	-	-	
Slot 5	-	-	-	-	
11. Save settings to SD					Copies saved values to SD
Slot 1	-	-	-	-	
Slot 2	-	-	-	-	
Slot 3	-	-	-	-	
Slot 4	-	-	-	-	
Slot 5	-	-	-	-	
12. Load settings from SD					Loads saved values from SD
Slot 1	-	-	-	-	
Slot 2	-	-	-	-	
Slot 3	-	-	-	-	
Slot 4	-	-	-	-	
Slot 5	-	-	-	-	
13. Test					For Service Personnel
13.1 Inputs	-	-	-	-	
13.2 Outputs	-	-	-	-	
14. Logout					

¹⁾ R/W = Read and write value, R = Read only value

13. MAINTENANCE

WARNING!



- When the unit needs to be opened ensure that the voltage to the unit is disconnected.
- Take care when opening the isolating valves for the hot water to the air heater. There is a risk of water hammer or steam discharge.
- When servicing or inspecting the unit, turn off the safety switch before opening the inspection doors. Reset all safety devices before restarting.
- Use the control panel to stop the unit.
- The unit's hatches are fitted with locking handles. Ensure that the unit is always left locked, and that the keys cannot be accessed by unauthorized persons.
- Do not open inspection hatches when the unit is in operation.
- Use protective gloves during installation and service.
- Use a full cover and protective gloves during service and maintenance

13.1 GENERAL

The customer is responsible for following and documenting the agreed maintenance and care measures. Follow the service schedule and fill in the measures that have been undertaken. Service must be carried out by an authorized service company. To maintain VDI compliance shall components which cannot be cleaned from fungus and mold be replaced.

SPARE PARTS

Spare parts and accessories for this air handling unit can be ordered from the nearest FläktGroup sales office. When ordering spare parts specify their codes according to the spare parts list.

INTERNAL CLEANING PROCESS

All surfaces and components shall be free from dirt and contaminant. Vacuum clean and dry off with a wet cloth. Use dish soap to clean the casing. Rinse with clean water after using detergent.

If necessary, disinfect the casing.

After cleaning make sure that all surfaces are dry. If the components cannot be cleaned, these must be replaced.

Important! Do not use acetone, chlorine or other similar detergents.

13.2 FILTER



As dust is separated out in the filter the pressure drop increases resulting in a reduced air flow. Regular filter replacement, with intervals determined by the concentration of dust in the air, is therefore necessary. The pressure drop can also be measured with the manometer RDTZ-07.

It is a good idea to mark the scale of the pressure gauge in red, above the value for the recommended final pressure drop. Order spare filters from your nearest sales office.

ORDERING CODES

Filter class F7 on both supply and extract air. Set with 2 filters.

Size 03 RDTZ-81-03-1

Size 04 RDTZ-81-04-1

Size 06 RDTZ-81-06-1

REPLACING A DIRTY FILTER (STEP BY STEP)

1. Use a dust mask (minimum class FFP2).
2. Remove the dirty filter. Clean the filter area according to internal cleaning process. Check that the seals are undamaged before fitting a new filter. Insert the new filter carefully.
3. Used filters must be disposed accordance with the local regulations regarding waste disposals.
4. Sort the filters for recycling.

FINAL PRESSURE DROP

SIZE 03

Air flow m ³ /s	0,15	0,25	0,35
Supply air/Extract air	119	148	177

SIZE 04

Air flow m ³ /s	0,30	0,40	0,50
Supply air/Extract air	125	142	159

SIZE 06

Air flow m ³ /s	0,40	0,55	0,70
Supply air/Extract air	121	139	157

13. MAINTENANCE

13.3 ROTARY HEAT EXCHANGER

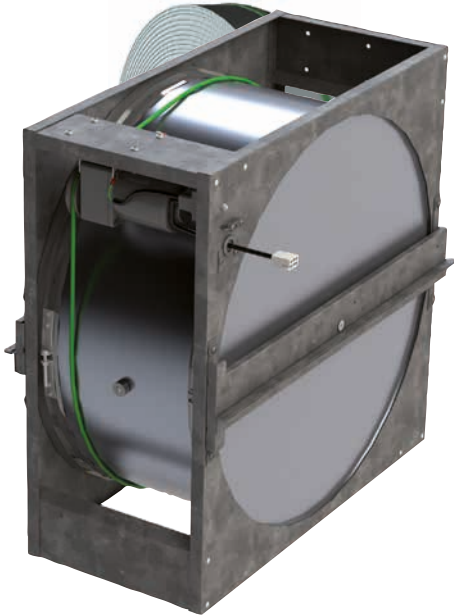

The rotary heat exchanger is very important for the operation and economy of the unit and must therefore be kept clean and in good condition.

The rotor is normally self-cleaning because the air flow is reversed when the rotor goes from supply to exhaust air.

The rotor is also provided with a purging sector that prevents extract air being carried into the supply air during rotation.

It is important for purging that extract air side has a lower pressure (bigger negative pressure) than the supply air side. There should be a 0-20 Pa bigger negative pressure on the extract air side. This ensures that the air leakage and purging flow goes towards the extract air, preventing pollution of the supply air.

The operation of the rotor (motor and belt) should be checked at least once every six months. The drive gearbox is lubricated for life.

The rotor shaft bearings are lubricated for life which means that no lubrication is required.

Check that the belt is not broken or slipping.

FRONT AREAS

Check that the surface of the wheel is not covered with dust. Clean by vacuuming or using compressed air.

Use the compressed air to blow away from the clean side towards the dusty side. If the dust is mixed with grease do as follows:

Spray a degreaser onto the dusty surface of the rotor, then blow clean from the opposite side using compressed air.

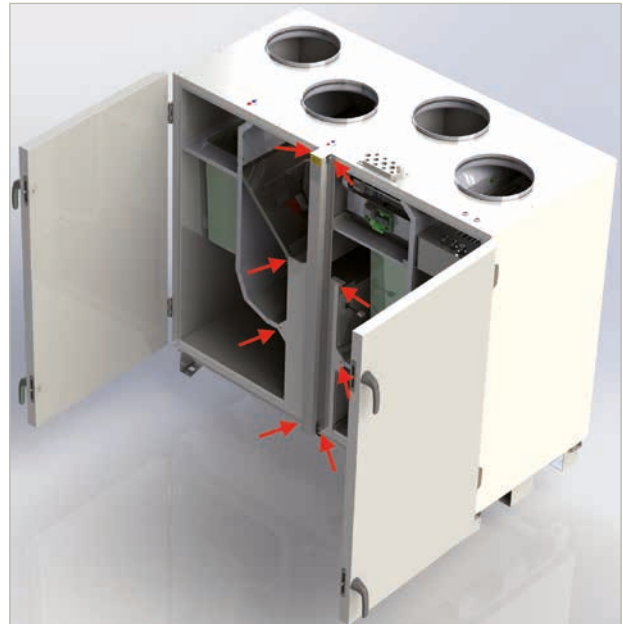

Removal of the center strut.

When cleaning by means of a high-pressure nozzle, direct the jet at right angles so the rotor face structure. The nozzle should preferably be held about 50 mm from the rotor face. The pressure should not be higher than 80 bar.

SEALING STRIP

The rotary heat exchanger is fitted with a sealing strip around the periphery and against the centre plane in order to reduce leakage between the supply air and extract air sides. Check that the entire length of the sealing strip is undamaged. Replace if necessary.

When cleaning, vacuum the brush sealing carefully

REPLACING THE DRIVE BELT

The rotor drive belt may need to be replaced due to wear. The drive belt is welded. One spare belt is supplied with the unit. Ensure that the belt is the correct length according to the table below.

Wear protective gloves when replacing the belt.

Size	Length, mm	Spare part code
03	1840	RDTP-99-15-03
04	2173	RDTP-99-15-04
06	2532	RDTP-99-15-06

13. MAINTENANCE

13.4 POST HEATER, HOT WATER

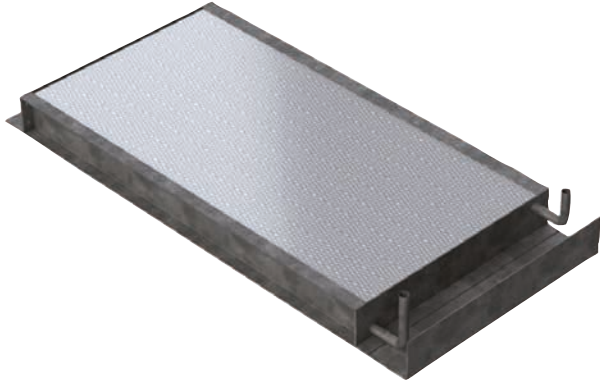

CLEANING

Despite effective air filters the fin surface can be covered with dust which prevents the air flow and impairs heat transfer. The heat exchanger must therefore be kept clean. This is best carried out using one or both of the following alternatives:

1. Blowing clean using compressed air.
2. Vacuum cleaning.

Remove all dust before starting the fan.

RISK OF FREEZING

If the water freezes in a heat exchanger it will burst. This means that water will run out of the system and cause water damage. There is a risk of freezing in ventilation systems at low outdoor temperatures in the following cases:

THE TEMPERATURE OF THE HEATING MEDIUM IS TOO HIGH

There is a particular risk of freezing especially in autumn and spring. Adjust the water temperature compared to the outdoor air temperature.

OVERSIZED HEAT EXCHANGER

Lower the water temperature to increase the water flow.

PROBLEM WITH SUPPLY OF THE HOT WATER

If the supply of hot water to the air heater can be expected to cease or decrease significantly, the outdoor air intake must be closed properly and all fans must be stopped.



NOTE! To avoid freezing the temperatures for frost protection must not be set too low.

If the building has to be left unheated for long periods during winter, the water must be drained from both the pipework and the heating coil.

DRAINING

Drain the unit through the pipe system.

VENTING

The air must be properly vented from the system to ensure good function. The venting is made through the pipe system.



Warning - hot water!

13. MAINTENANCE

13.5 POST HEATER, ELECTRICAL



GENERAL

Units with an electric air heater may be installed in dry rooms not subject to the risk of fire or explosion and in garages where petrol is not normally filled.

The maximum air temperature after the heater is +40°C.

The air heater is fitted with two independent thermostats. One overheat protection thermostat with a manual reset, and one temperature limiting thermostat with an automatic reset.

If the temperature in the heater exceeds the set value for manual overheat protection, the unit will stop and an alarm will occur.

If the temperature in the heater exceeds the set value for the automatic overheat protection, the heater will be turned off. When the temperature drops the heater will be turned on automatically.

MAINTENANCE

The electric air heater is fitted with tubular heating rods. No maintenance is necessary apart from periodic performance testing.

Check that the heating rods are not covered with dust as this could lead to odors and in the worst case fire.

If necessary clean by vacuuming or wiping. Only qualified service personnel is allowed to open the cover of the electrical heater.

OVERHEATING

If thermal overload protection with a manual reset has tripped carry out the following.

Turn off the safety switch. Only qualified service personnel is allowed to open the cover of the electrical heater.

Investigate the reason that the thermal overload protection tripped.

When the fault has been corrected reset the thermal overload protection.

13.6 WATER COOLING COIL, DUCT MOUNTED



CLEANING

Despite effective air filters the fin surface can be covered with dust which prevents the air flow and impairs cooling transfer. The cooling coil must therefore be kept clean. This is best carried out using one or both of the following alternatives:

1. Blowing clean using compressed air.
2. Vacuum cleaning.

Remove all dust before starting the fan. Clean the air cooler drainage tray if necessary. Also check that the drain trap is clean and filled with water.

DRAINING

Drain the unit through the pipe system.

VENTING

The air must be properly vented from the system to ensure good function. The venting is made through the pipe system.

13. MAINTENANCE

13.7 FANS



MAINTENANCE

Make an inspection and if necessary clean the fan according to Service Schedule, section 13.8..



Important! Turn off the safety switch and wait for the impeller to stop before inspection and service.

CLEANING

The best way to clean the impeller is to use a vacuum cleaner attached with a soft dusting brush. To prevent imbalance, clean all fan blades carefully. After the cleaning check that the fan runs without vibrations.

PRECAUTIONS BEFORE STARTUP

Before startup, check that the impeller rotates freely and that there are no foreign objects which could be drawn into and damage the fan.

LUBRICATING THE FAN MOTOR

The fan motor bearings are factory lubricated and maintenance free.

REMOVAL OF FAN

1. Disconnect the control cable with fittings.

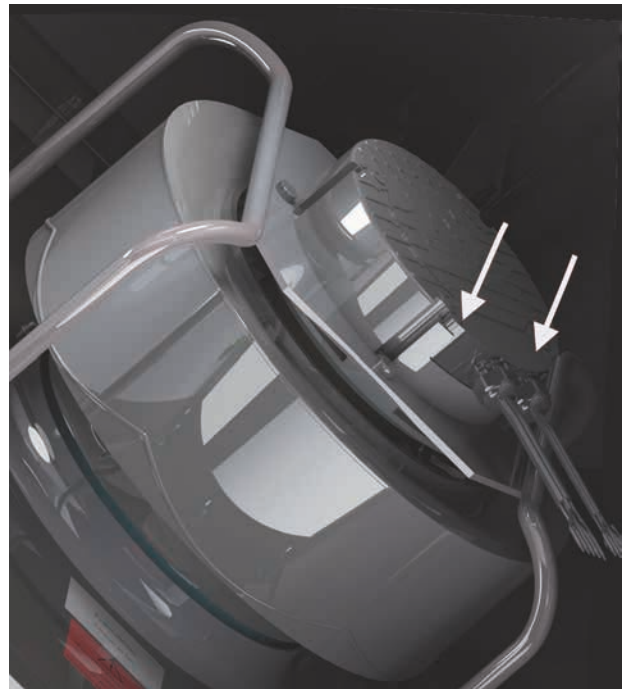

2. Remove the nuts from the fan.

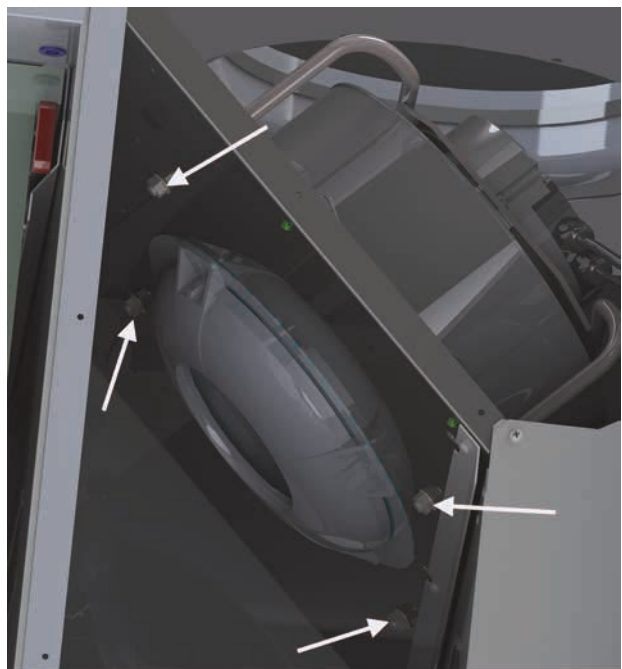

3. Remove the fan.

13. MAINTENANCE

13.8 SERVICE SCHEDULE INSPECTION INTERVALS







The service schedule covers service and inspection intervals for the components of an air handling unit. The unit contains one or more of these components. Delete components that are not applicable from the service schedule.

Date and sign every service.

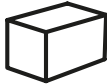
The length of the service interval is calculated on the basis of approximately 2000 operating hours in a 12 month period for a normal AHU installation.

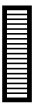
In dirty environments, the maintenance of the unit has to take place more often.

Applies from 20 to 20

Symbol	3-month/9-month service			6-month service		12-month service	
	Action	Month	Date/ Signed	Action	Date/ Signed	Action	Date/ Signed
Air Handling unit 	Cleaning	3		Cleaning		Cleaning	
		9					
Filter 	Checking pressure drop and any filter replacement .	3		Checking pressure drop and any filter replacement .		Checking pressure drop and any filter replacement .	
		9					
Rotary heat exchanger 	General service. Checking seals.	3		Cleaning rotor		Cleaning rotor. Checking monitoring equipment .	
		9					
Fan 	General service	3		General service		Cleaning impeller, casing, unit casing. Checking bearings.	
		9					
Damper 	Checking operation and gasket. Replace gasket if necessary.	3		Checking operation and gasket. Replace gasket if necessary.		Checking operation and gasket. Replace gasket if necessary.	
		9					
Air heater Air cooler 	General service	3		Cleaning heat exchanger and electric heating rods.		Cleaning heat exchanger, electric heating rods, drainage tray and casing.	
		9					
Silencer 	Cleaning as necessary	3		Cleaning as necessary		Cleaning as necessar	
		9					
Casing				Internal cleaning as necessary.		Check door seals. Internal cleaning.	

14. DECLARATION OF CONFORMITY



ENCLOSURE II A

Försäkran om maskinens överensstämmelse Declaration of Conformity

med EG:s Maskindirektiv / with the EU Directive for Machinery, 2006/42/EC
EG:s EMC Direktiv / with the (EMC) Directive, 2014/30/EU
EG:s Direktiv för energirelaterade produkter /
EU Directive for Energy related Products ErP 2009/125/EC

**Tillverkaren
Manufacturer** FläktGroup Sweden AB
Fläktgatan 1
551 84 Jönköping

Försäkrar härmed att: / Herewith declares that:

**Produkten
Product** Typ / Type: Ventilationsaggregat / Ventilation Unit
Fabrikat / Manufacturer: FläktGroup Sweden AB
Varunamn / Commercial name: eCO TOP, RDTP / eCO SIDE, RDSP

Maskinen är konstruerad och tillverkad i enlighet med följande standarder, i tillämpliga delar.
The machine is designed and manufactured in accordance with the following standards, in relevant parts.

EN ISO 12100	Maskinsäkerhet – Allmänna konstruktionsprinciper – Riskbedömning och riskreducering Safety of machinery – General principles for design- Risk assessment and risk reduction
EN 60204-1	Maskinsäkerhet – Maskiners elutrustning, Del 1: allmänna fordringar Safety of machinery; electrical equipment of machines; general requirements
EN 61000-6-2	Elektromagnetisk kompatibilitet (EMC) - Del 6-2: Generella fordringar - Immunitet hos utrustning i industrimiljö Electromagnetic compatibility (EMC) - Part 6-2: Generic standards – Immunity standard for industrial environments.
EN 61000-6-3	Elektromagnetisk kompatibilitet (EMC) - Del 6-3: Generella fordringar - Emission från utrustning i bostäder, kontor, butiker och liknande miljöer. Emission standard for residential, commercial and light-industrial environments.
EN 13053:2006	Luftbehandling – Luftbehandlingsaggregat – Klassificering av och bestämning av prestanda för aggregat, aggregatdelar och komponenter. Ventilation for buildings – Air handling units – Ratings and performance for units, components and sections
EN 1886:2007	Luftbehandling – Luftbehandlingsaggregat – Mekaniska egenskaper Ventilation for buildings – Air handling units – Mechanical performance

För produkten har riskanalys upprättats enligt krav i Maskindirektivet. /
A risk analysis has been made according to requirements of the Directive for Machinery.

**Behörig
Authorized** Att sammanställa teknisk dokumentation:
To prepare technical documentation:
Anders Jacobsson – R&D Director
FläktGroup Sweden AB
Fläktgatan 1, 551 84 Jönköping

Försäkran gäller endast om installation av aggregatet skett enligt FläktGroups instruktioner och förutsatt att inga ändringar gjorts på aggregatet.
The declaration applies only to the installation made according to FläktGroups instructions and assuming no changes made to the unit.

Jönköping 2019.01.01

Björn Norling, Quality Manager, FläktGroup Sweden AB, Jönköping

FläktGroup Sweden AB

Postal Address
FläktGroup Sweden AB
S-551 84
Sweden

Street Address
Fläktgatan 1
Jönköping

Telephone
Nat 036 - 19 30 00
Int +46 36 19 30 00

Telefax
Nat 036 - 19 31 40
Int +46 36 19 31 40

Reg. no:
556239-2463
Reg. office:
Jönköping

99605E_GB_RDTP Declaration of conformity(2A)20190101

15. DISPOSAL OF PRODUCT AND PACKAGING MATERIALS

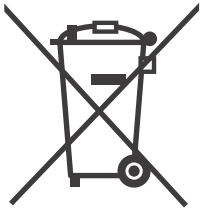

Recycling should be made in accordance with local regulations. When the product is scrapped the following parts/components/materials shall be sorted. Depending on what product it is may not all parts/components/materials be represented.

- Printed circuit boards, cables, batteries, motors, sensors etc.
- Filters, except made of pure metal (in cooker hoods).
- Packaging materials, such as cardboard, plastic and styrofoam.
- The units casing may contain condense- or mineral wool insulation sandwiched between the inner and outer shell.
- The remaining parts shall be sorted as metallic.
- Lamps and fluorescent lights.

See www.flaktwoods.com for recycling instructions.

EXCELLENCE IN SOLUTIONS

FläktGroup is the European market leader for smart and energy efficient Indoor Air and Critical Air solutions to support every application area. We offer our customers innovative technologies, high quality and outstanding performance supported by more than a century of accumulated industry experience. The widest product range in the market, and strong market presence in 65 countries worldwide, guarantee that we are always by your side, ready to deliver Excellence in Solutions.

PRODUCT FUNCTIONS BY FLÄKTGROUP

Air Treatment | Air Movement | Air Diffusion | Air Distribution | Air Filtration
Air Management | Air Conditioning & Heating | Controls | Service

» Learn more on www.flaktgroup.com
or contact one of our offices